

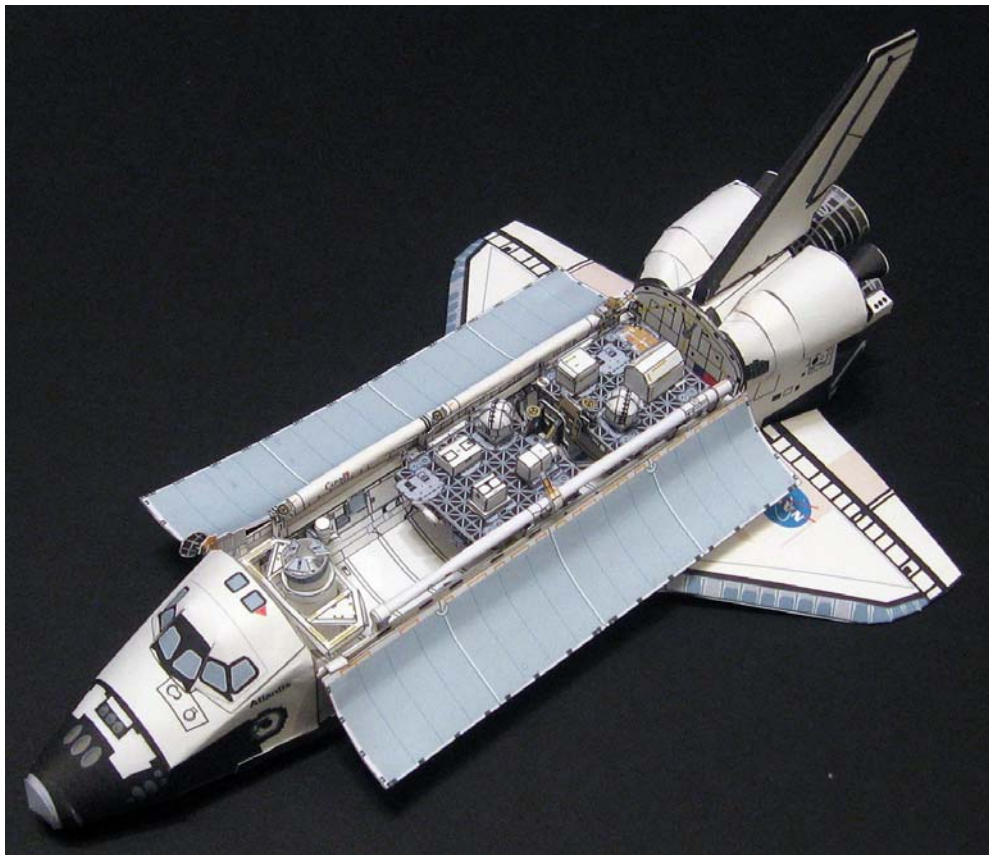

© 2010

Assembly Instructions for STS-129 payload



Overview of the Express Logistic Carriers 1 & 2 in the payload bay

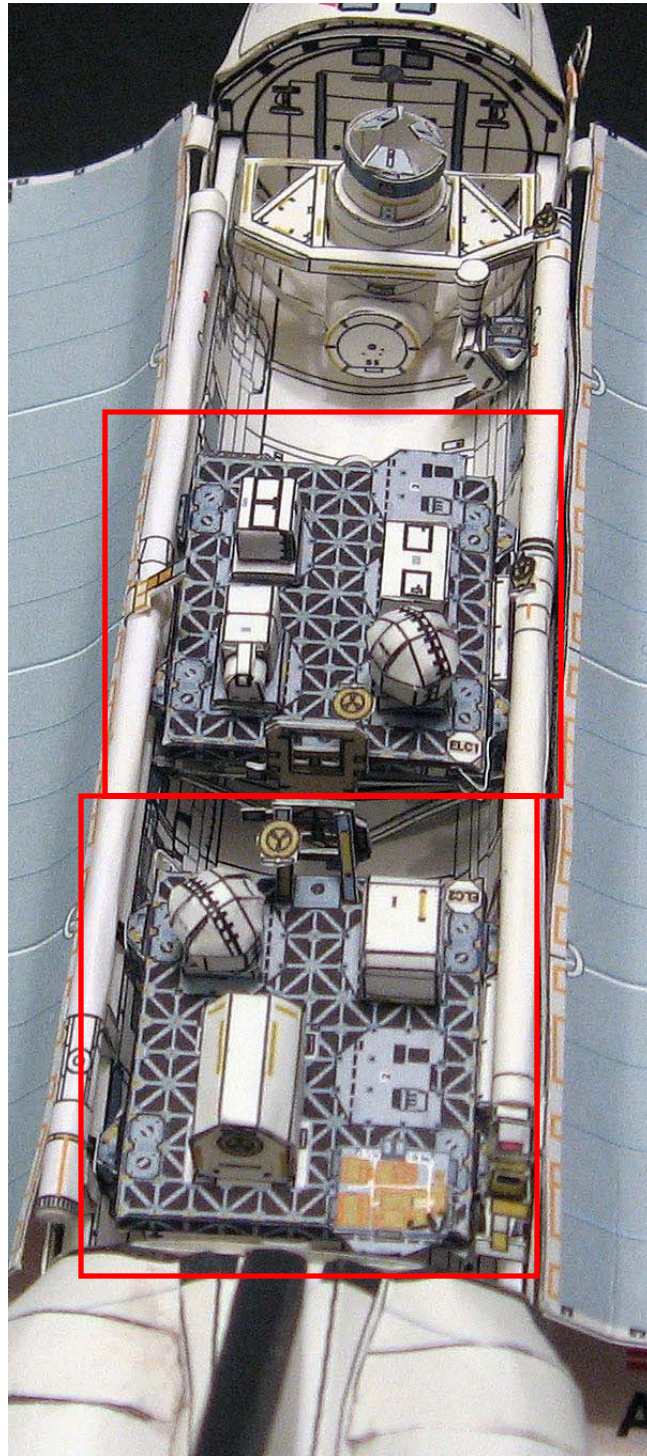

ELC-1

ELC-2

Building the ELC platform

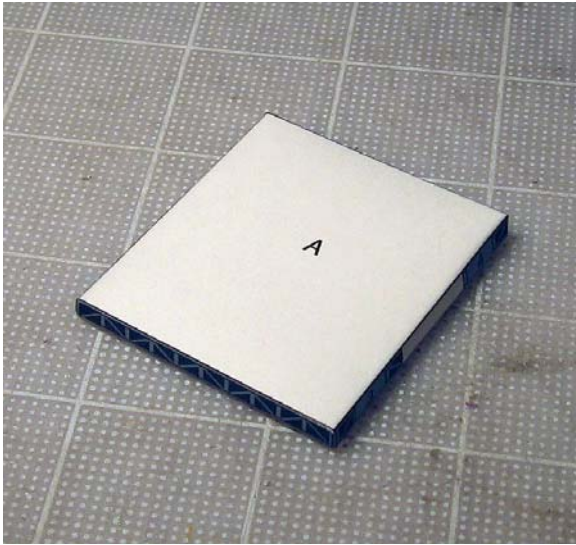

Each platform consists of a flat box and 2 covers A and B. Each side has markings that will help when gluing each cover. Look at the corner that says either ELC-1 or ELC-2 and glue the cover in the same orientation matching the corners.

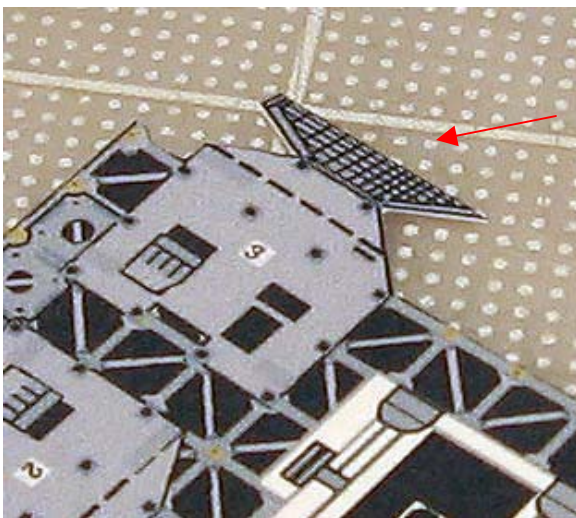
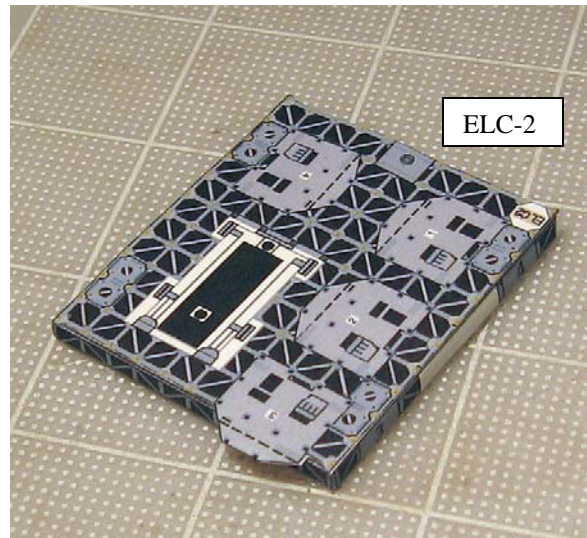
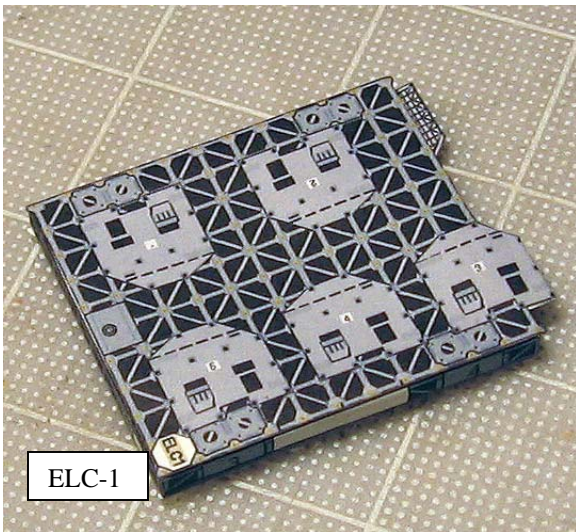

Fold the tabs where indicated and glue back to back.

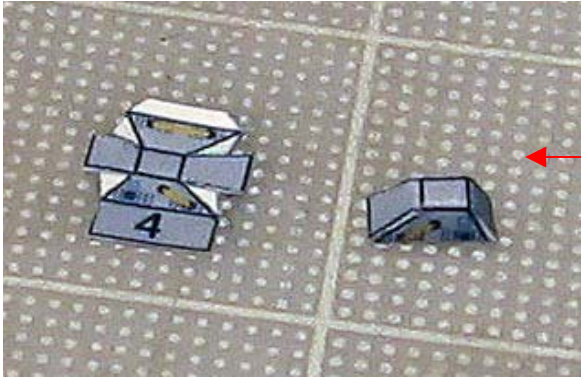

This is one of the 4 trunnions supports that go on each corner. Match the orientation of the numbers in order to glue them to the platform.

Also glue the white box on the side.

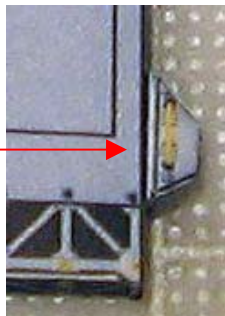
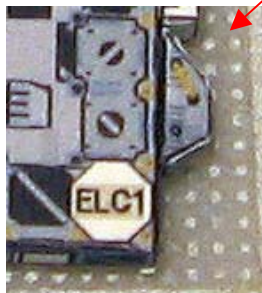
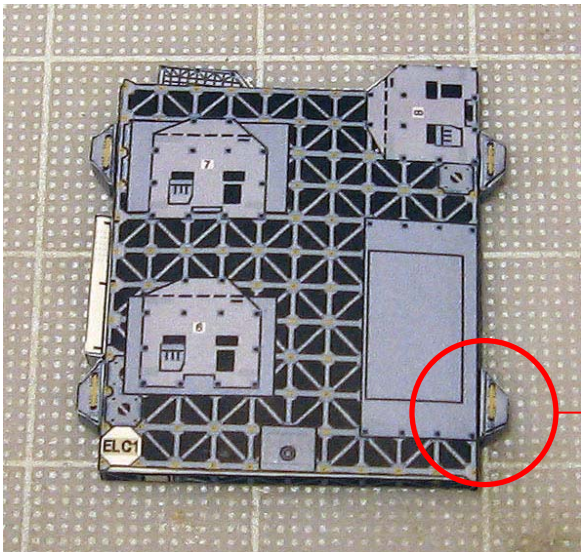
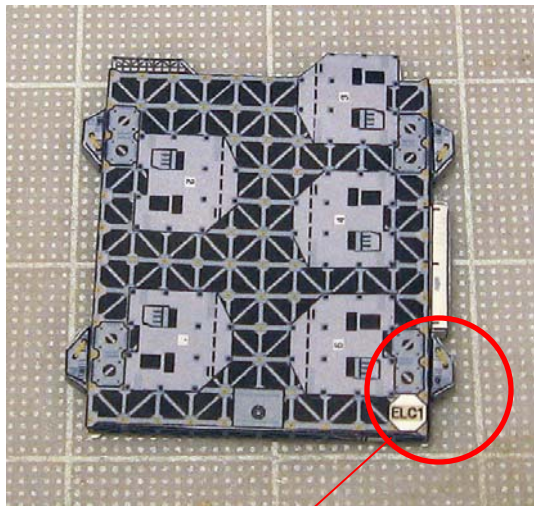
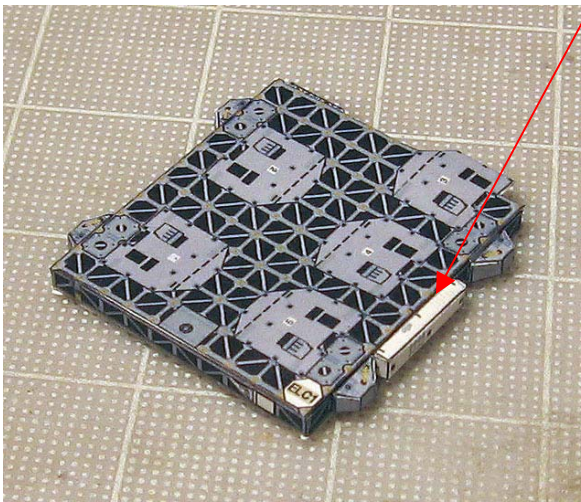

Note the orientation of the handrail drawing. The short diagonal handrail is for the top side of the platform. The straight handrail indicates the underside or keel side of the platform.



Then glue each trunnion to each support on each corner.

Building the attachment faces

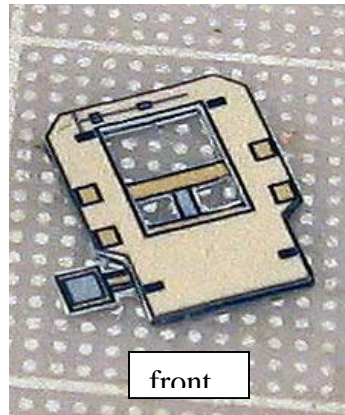
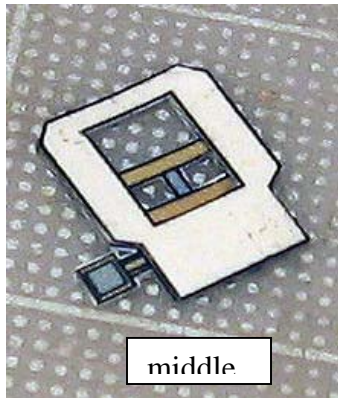
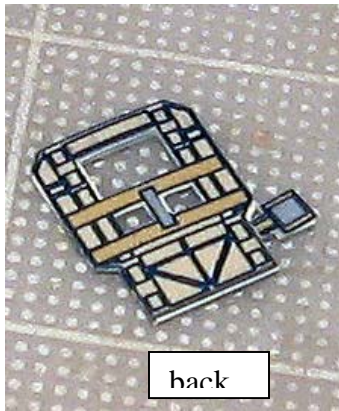

The 3 photos shown above depict the attachment face for each platform. Use a blade to cut the small windows. Below is a sample of one of the 2 supports for each attachment face. The difference between ELC-1 and ELC-2 is the opposite direction that each attachment face has.



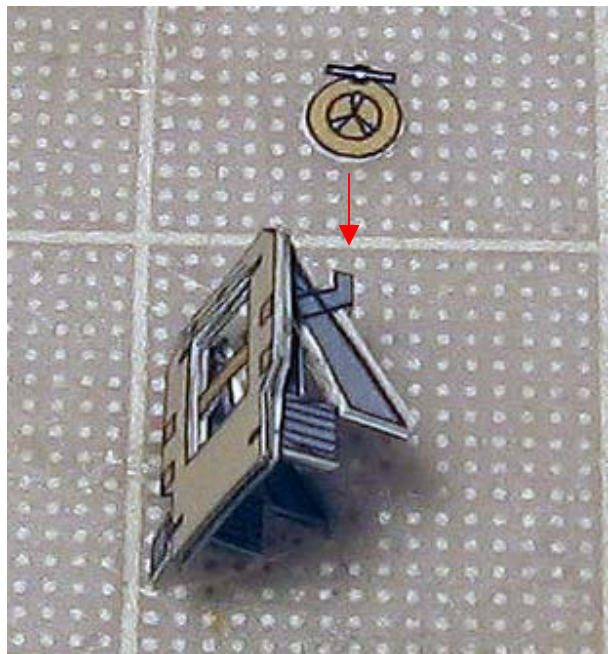
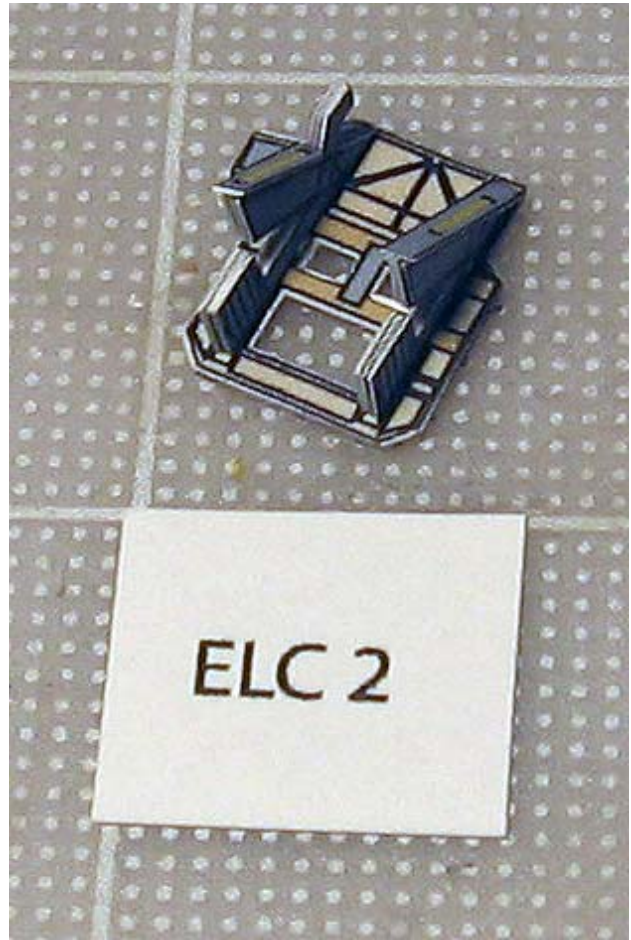
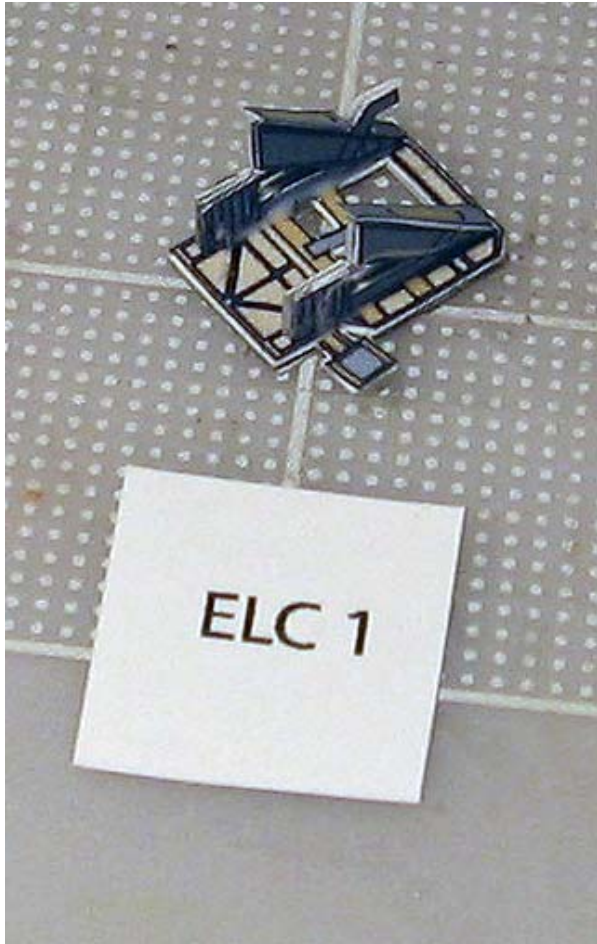

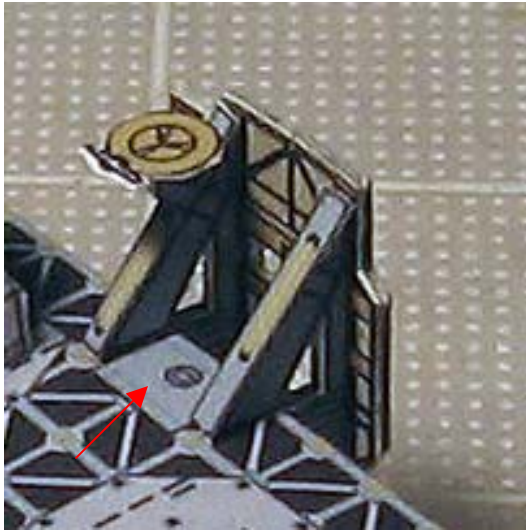
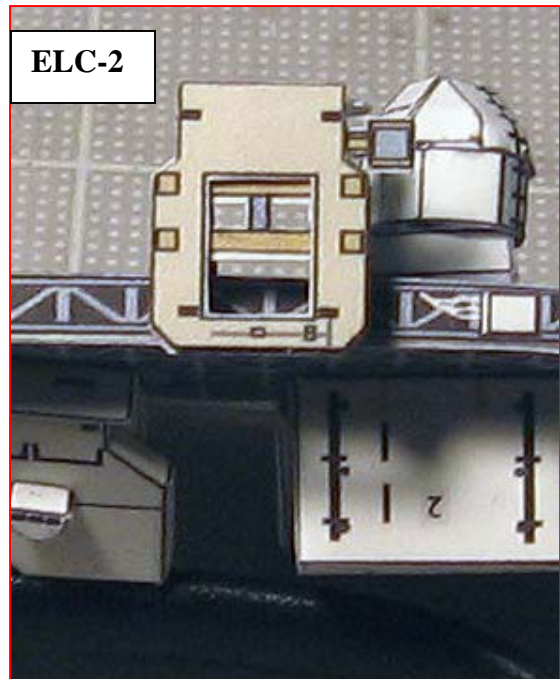
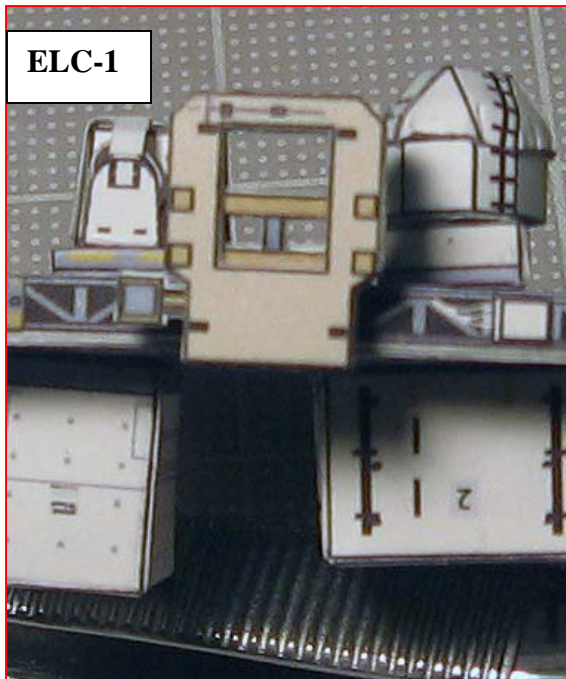
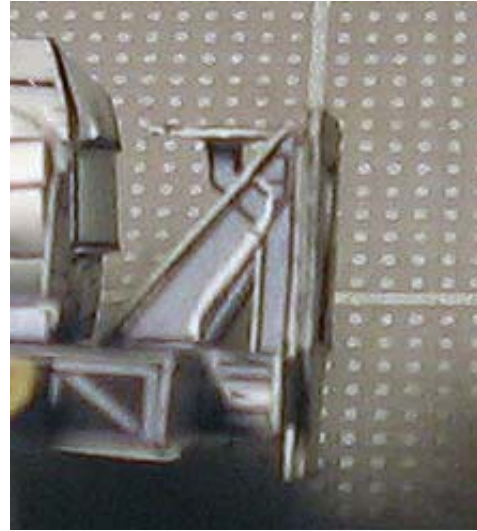
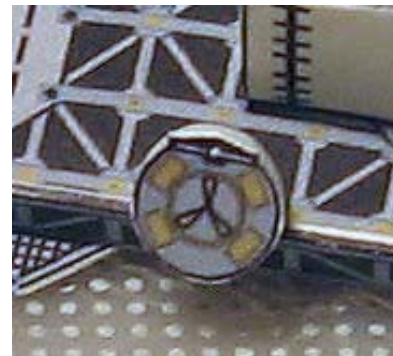
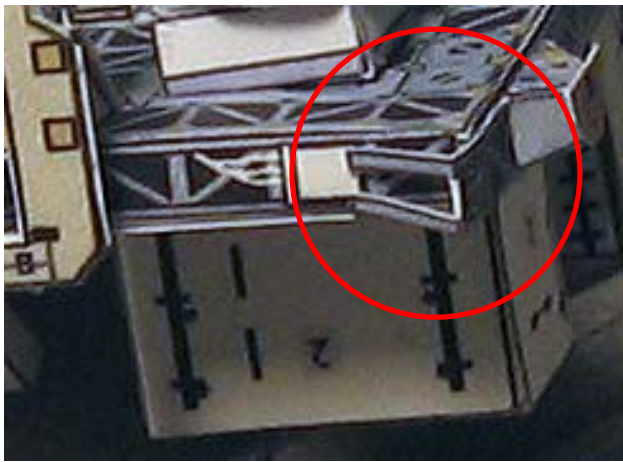

Photo shows where this attachment face is glued on the platform. The arrow points a square plate for reference.



Main difference between ELC-1 and ELC-2 (orientation of the attachment face)



The Power and Data Grapple Fixture is glued on the keel side in an angle.

ELC-1

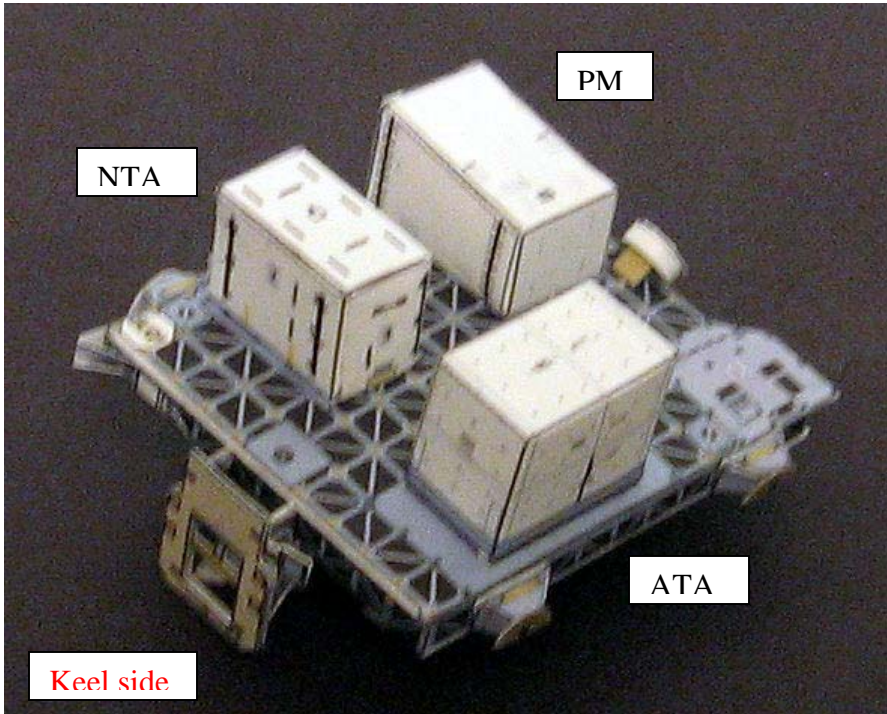
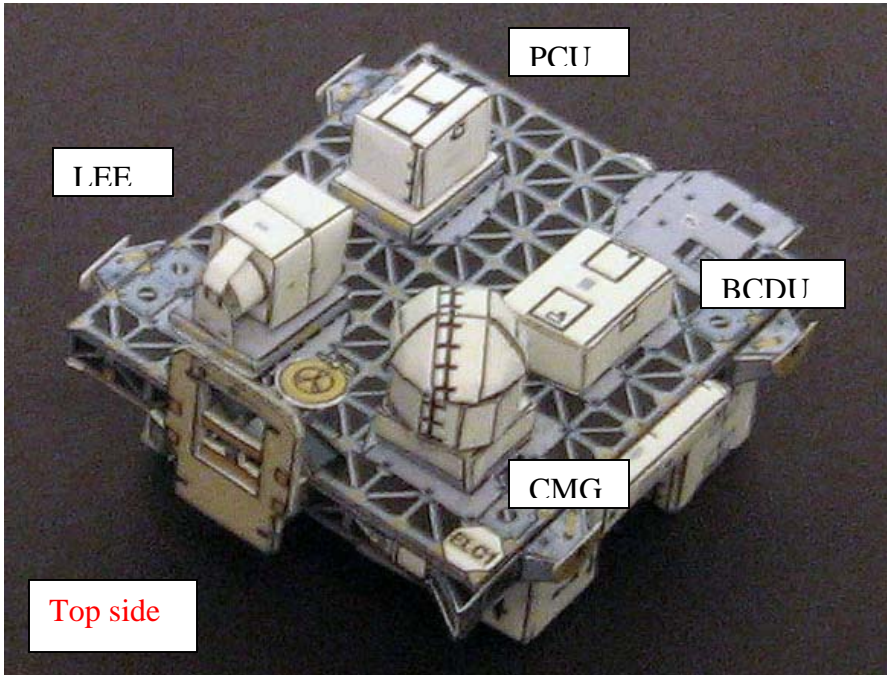

ELC-2

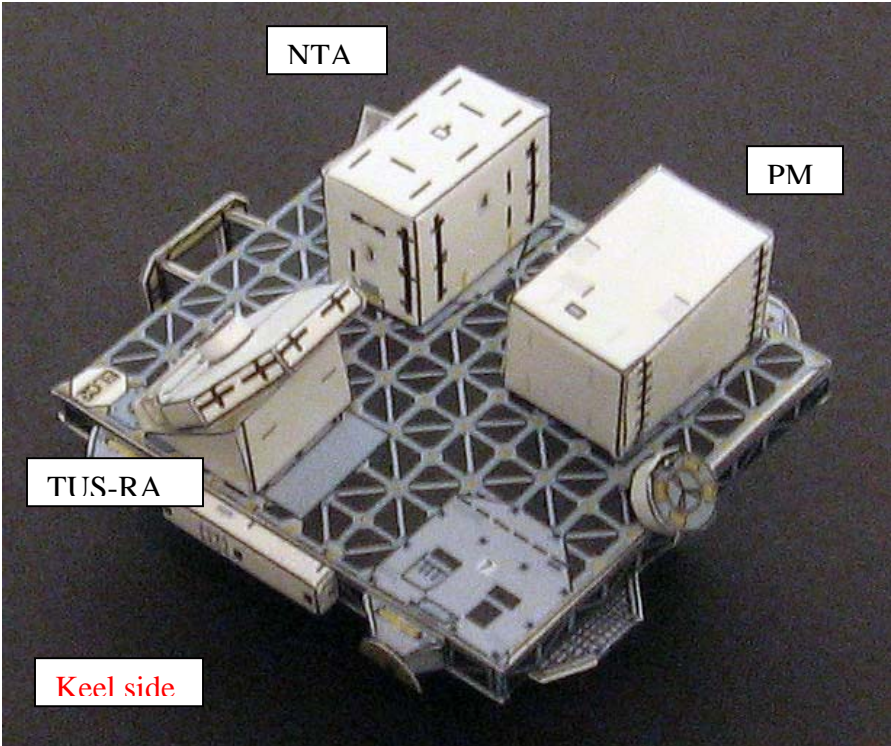
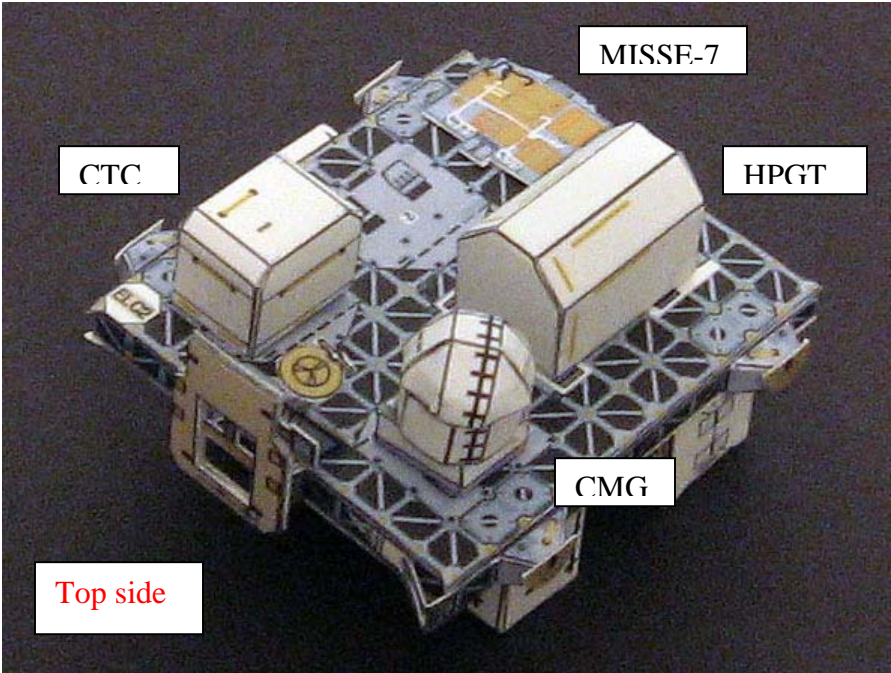

ORU's (Orbital Replacement Units)

This manual will focus on building specific ORU's because of their complexity. The other ORU's are simple boxes.

Building the CMG (Control Moment Gyro)

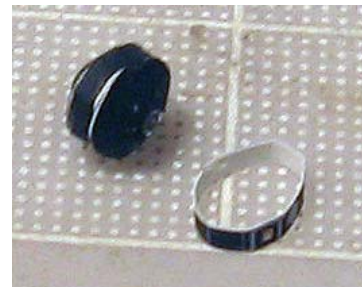
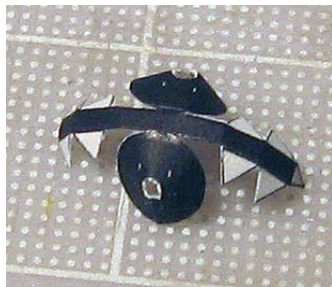
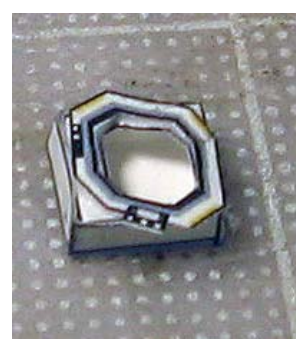
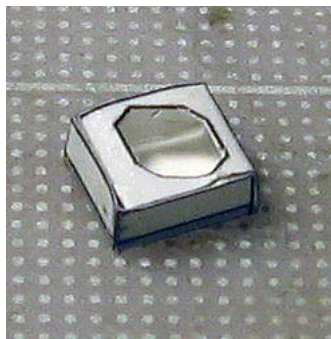
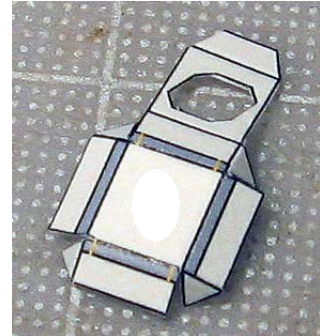
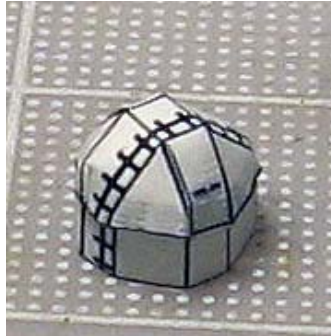
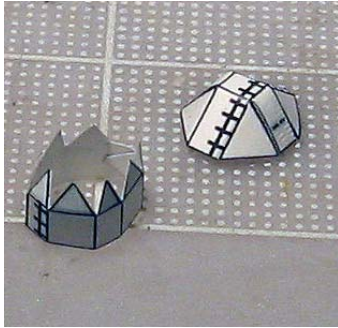
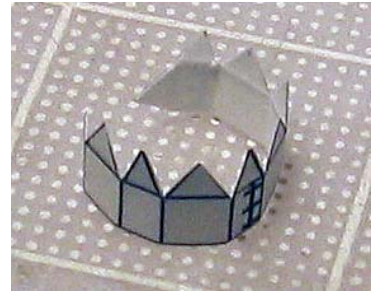
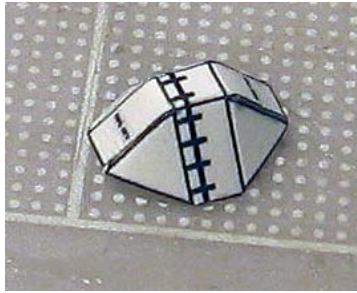
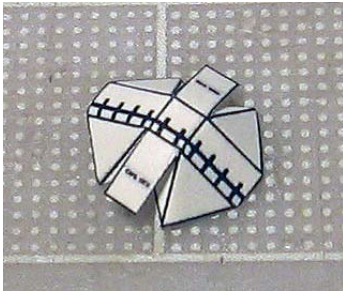



Building the LEE (Latching End Effector)

Steps for 1:100 scale model only

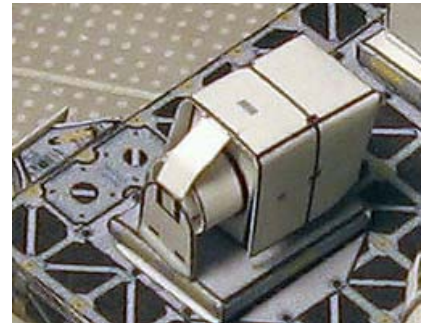
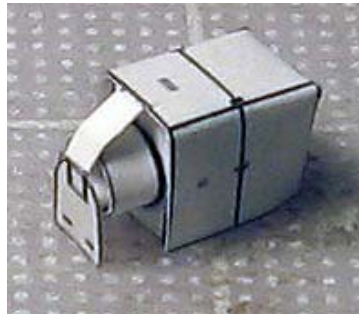
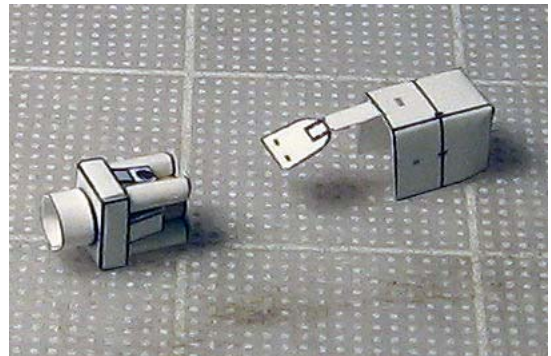
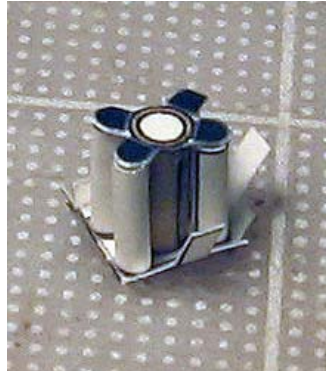
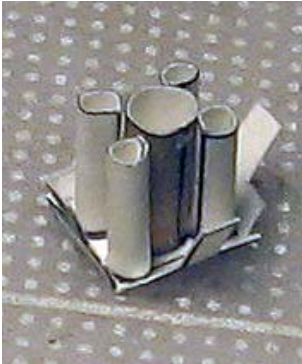

Building the TUS-RA (Trailing Umbilical System – Reel Assembly)

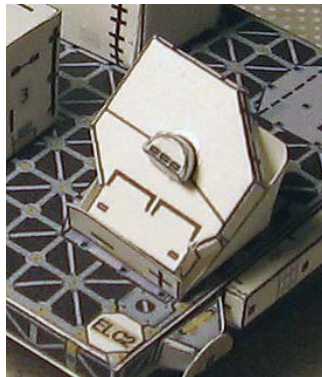
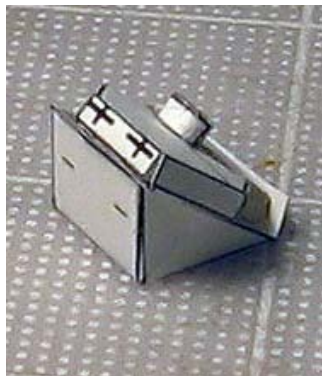
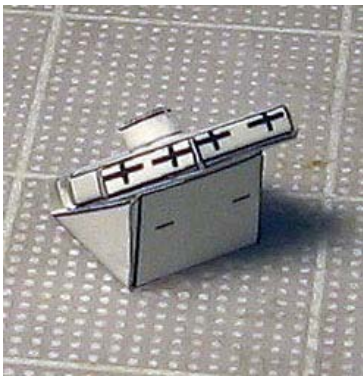
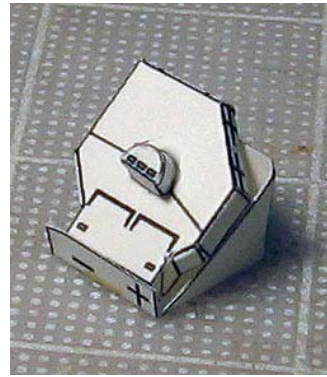
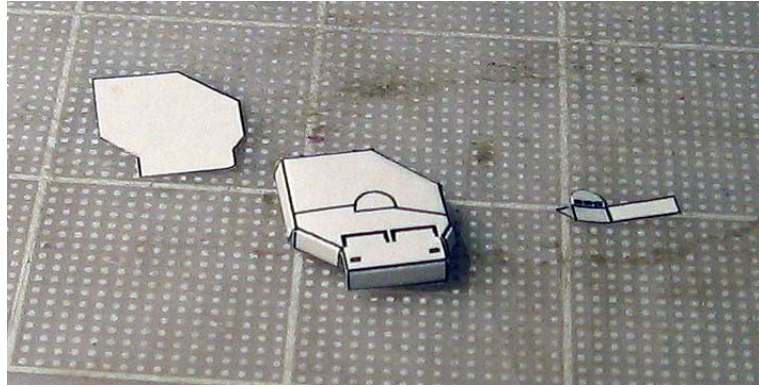

Building the MISSE-7

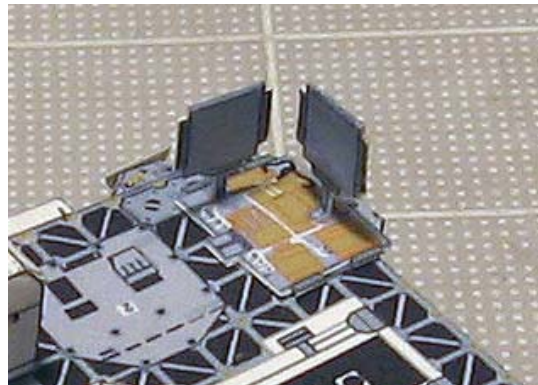
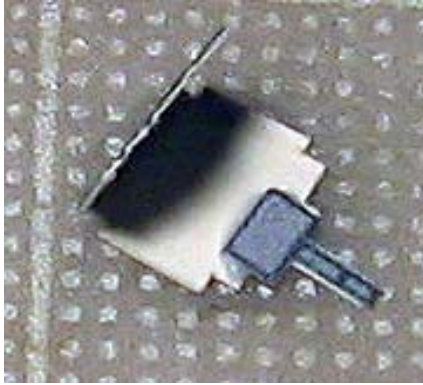

MISSE-7 assembled on ELC-2

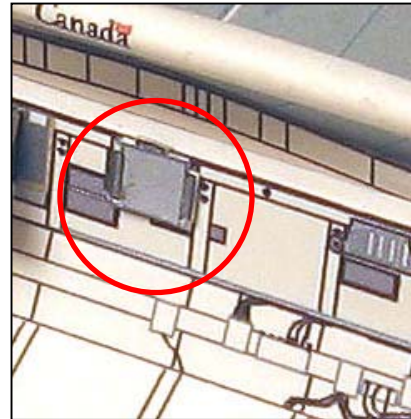
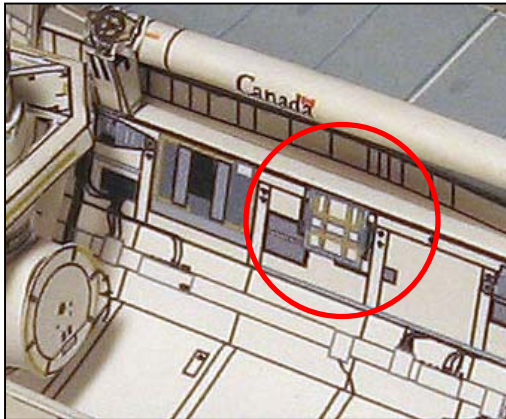

MISSE-7 in the payload bay

Building the PCU (Plasma Contactor Unit)

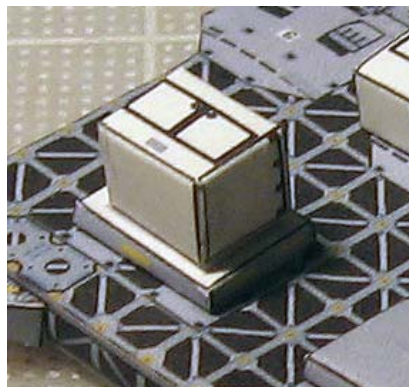
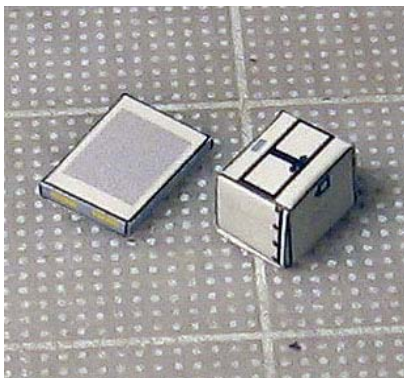

Building the SASA antennae

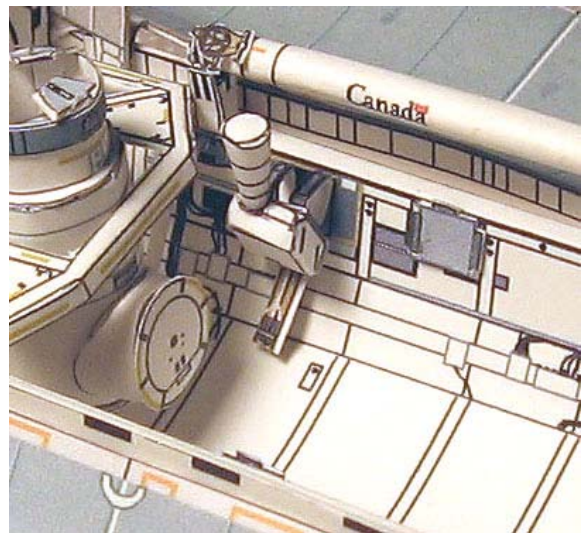
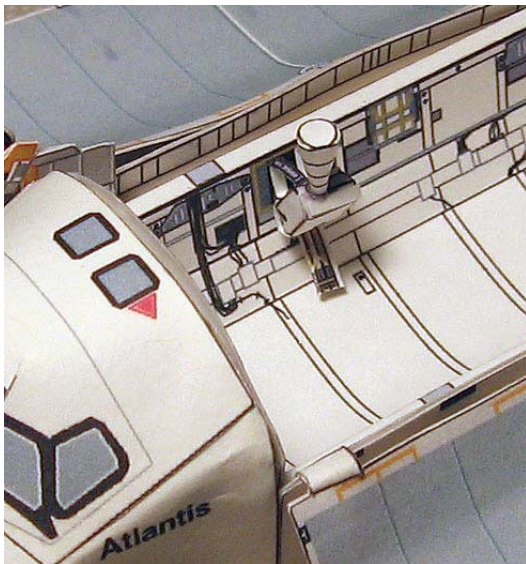
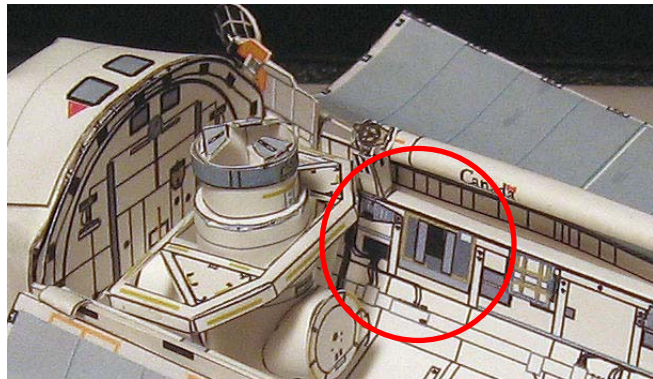

Installing the Airlock MMOD (micro-meteoroid) Shields on ESP-2

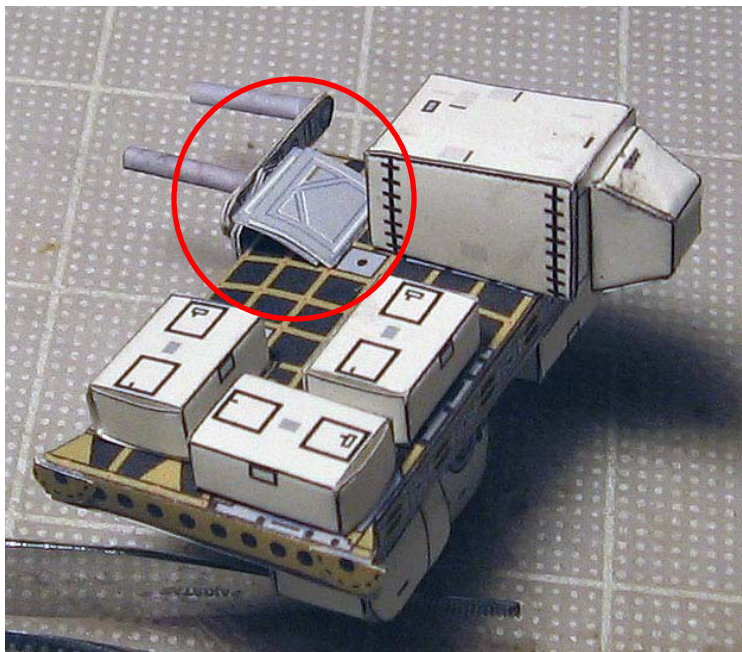
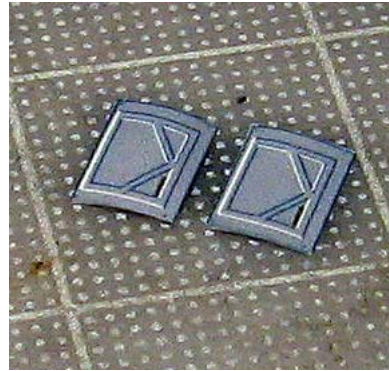
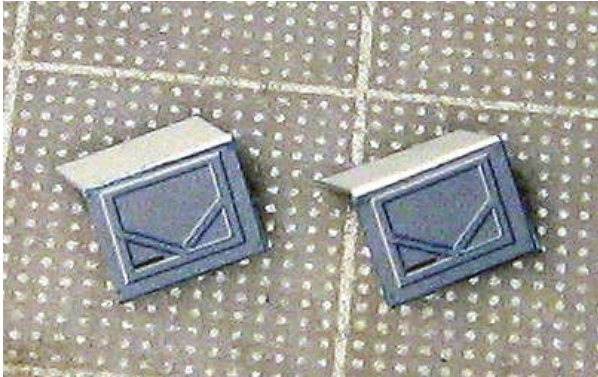

These shields are temporarily stowed on ESP-2 and will return to Earth on a future Shuttle mission, therefore use very little glue so they can be detached easily.

Installing the new HPGT on “QUEST” Airlock

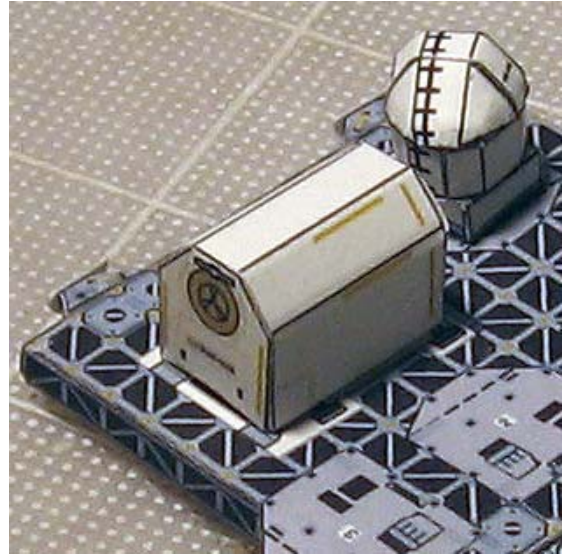
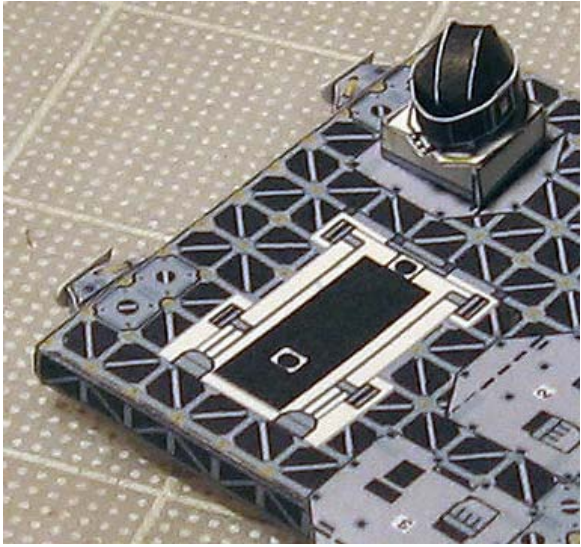

This is the upper deck of ELC-2 showing the location where the HPGT is glued, only for Payload bay configuration. But once the ELC-2 is attached to the ISS, the HPGT is not glued. Instead, it will be glued to QUEST Airlock.

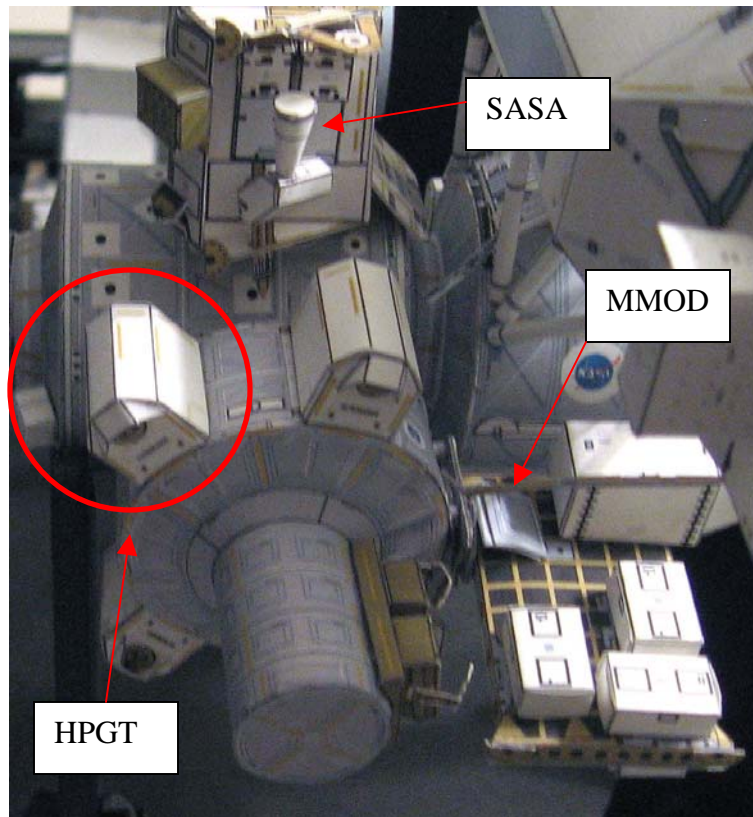

How to attach the ELC's to the ISS

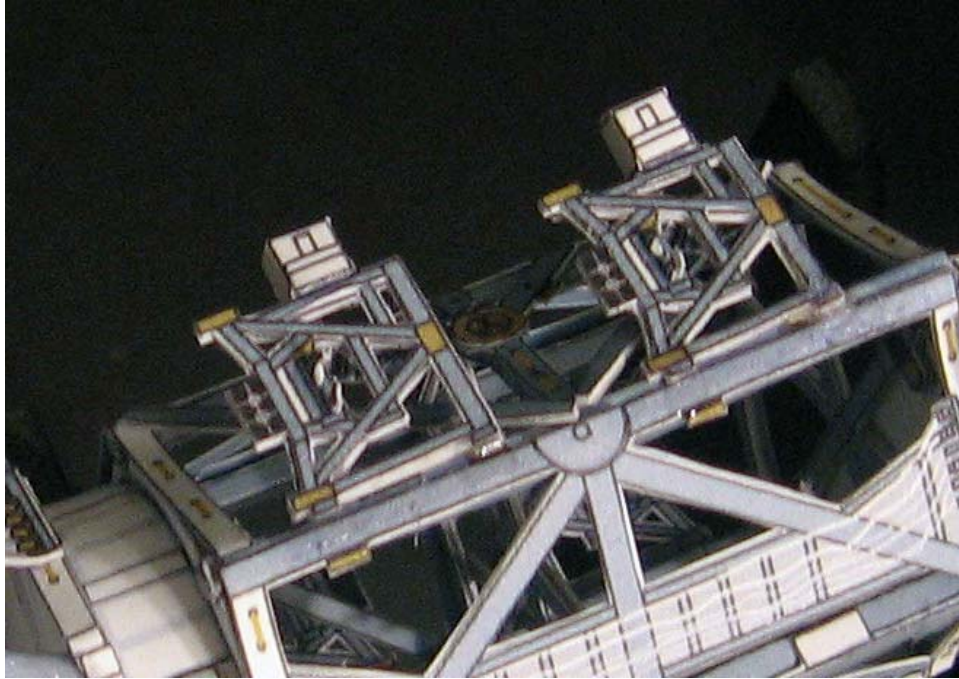

In order to attach ELC-1 and ELC-2 to the ISS, you need to get mission kits STS-115 and STS-117 combo (future release). This is a photo of the S3-S4 truss from STS-117. It clearly shows the attachment points (UCCAS/PAS).

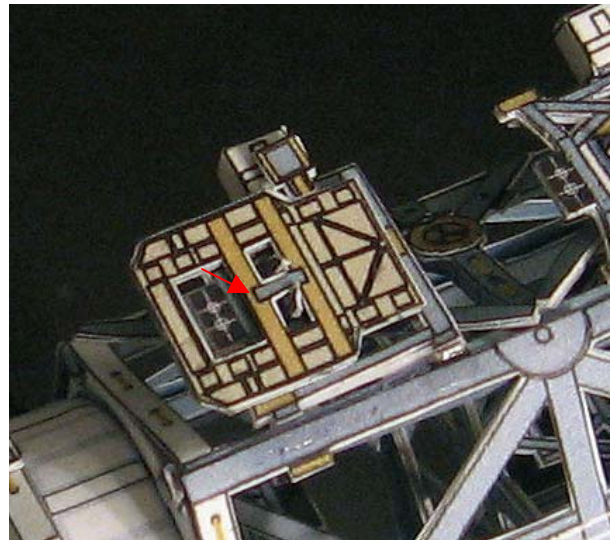
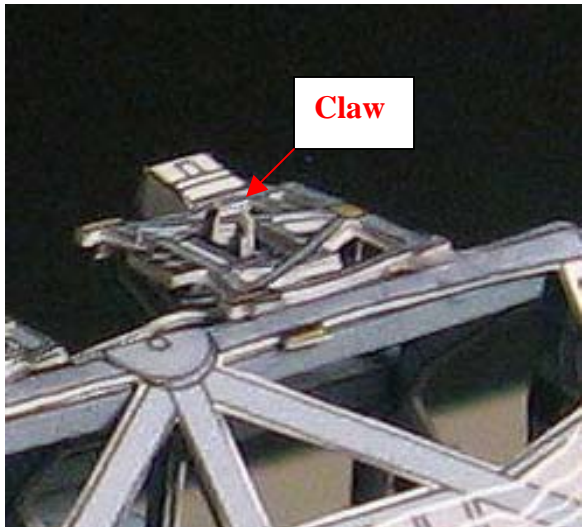

This photo demonstrates how the attachment face of the ELC is connected to the UCCAS/PAS. The **claw** of the UCCAS will insert through the 2 small windows and will grab tight with the **small vertical bar** (arrow). You can use glue or not.

Location of ELC-1

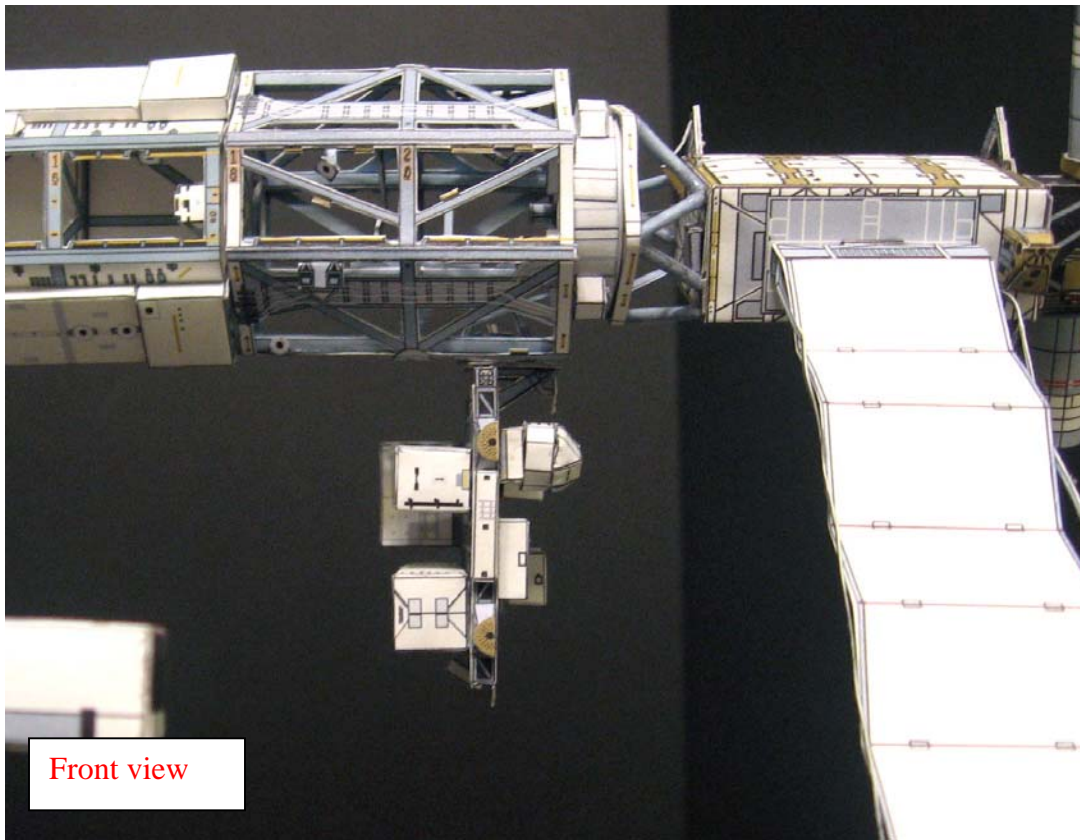
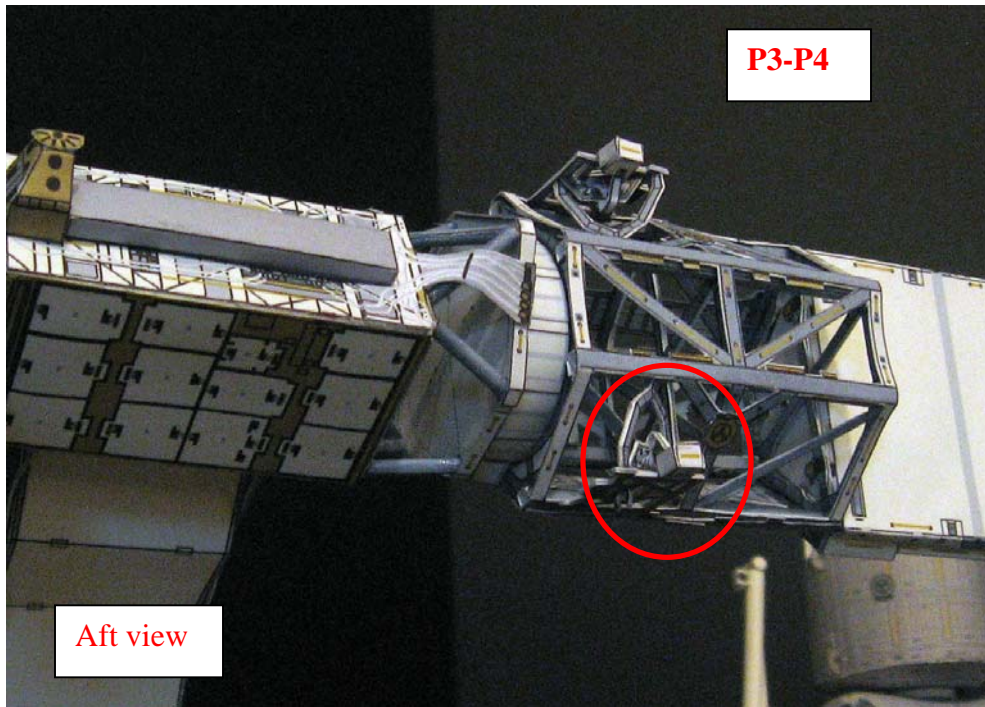

Location of ELC-2

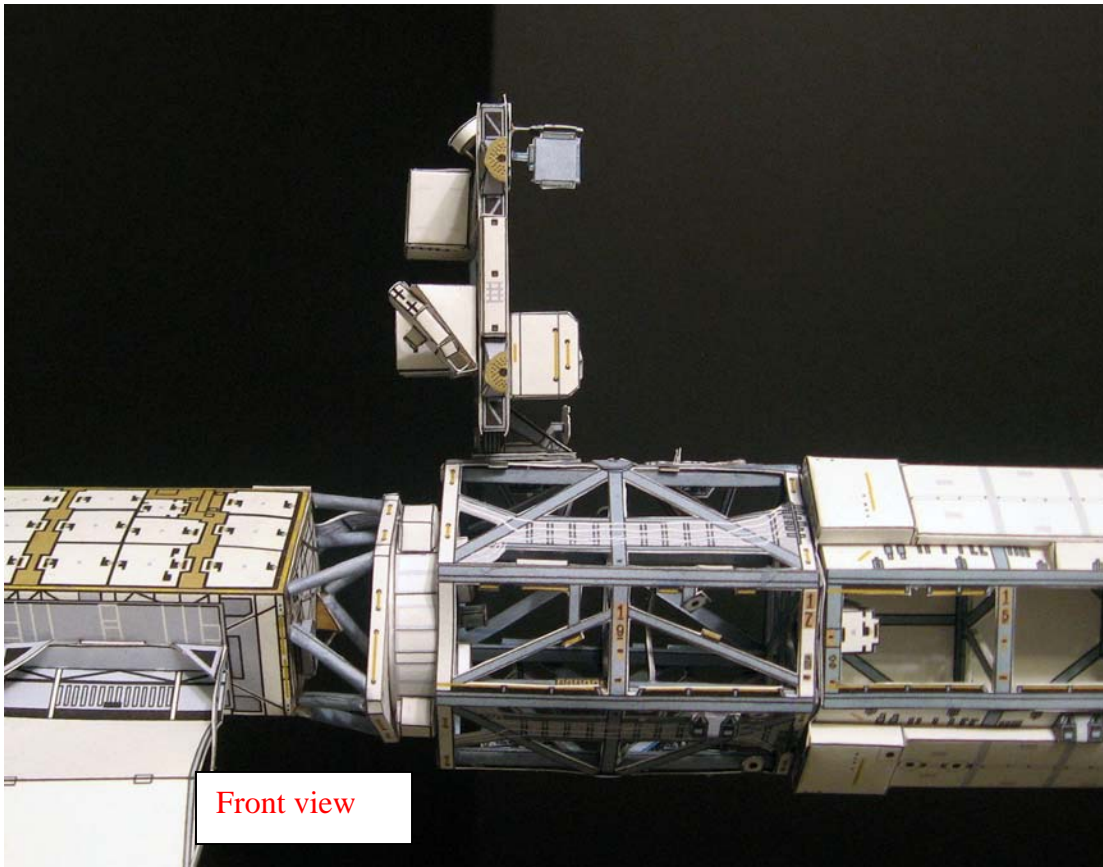
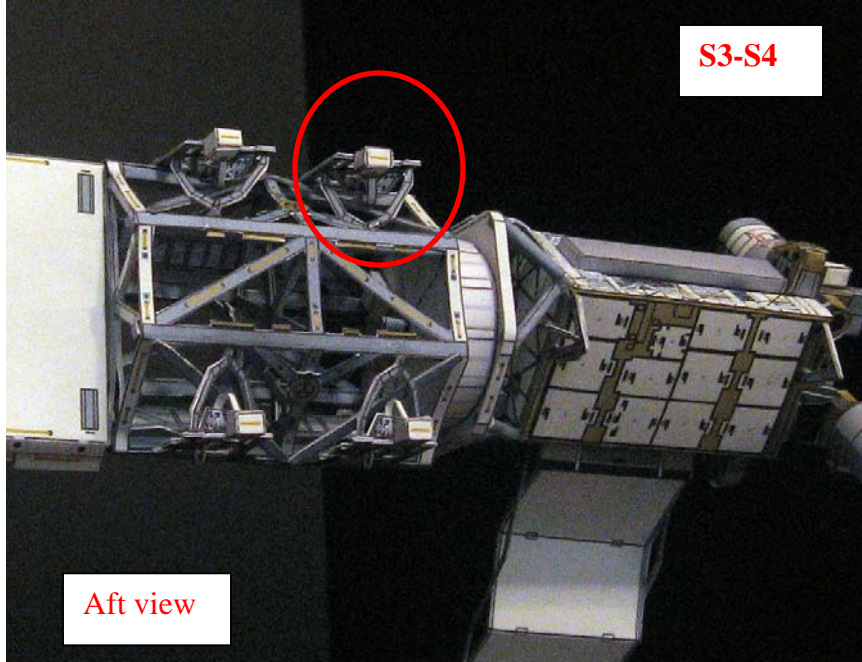

REFERENCE PHOTOS

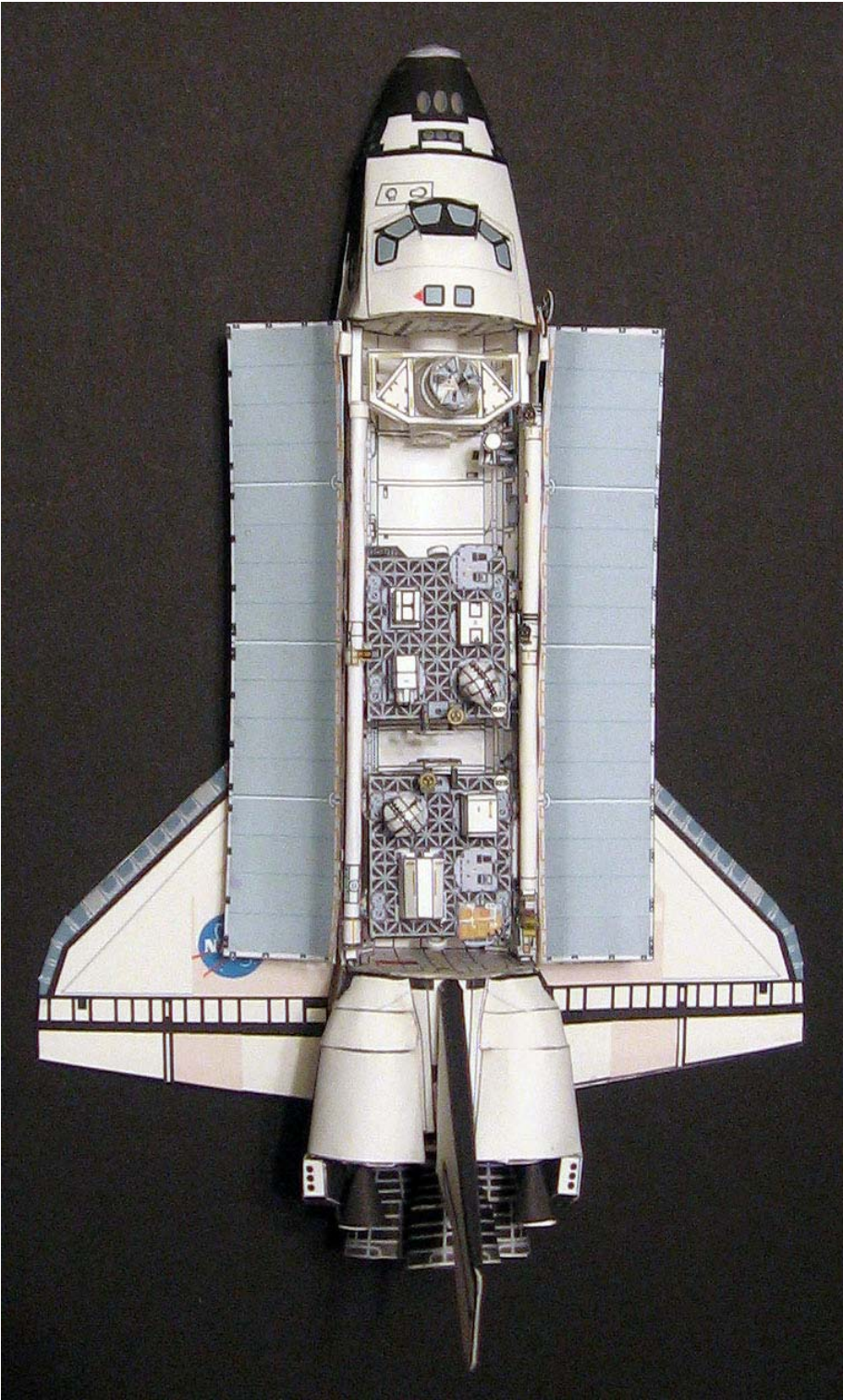

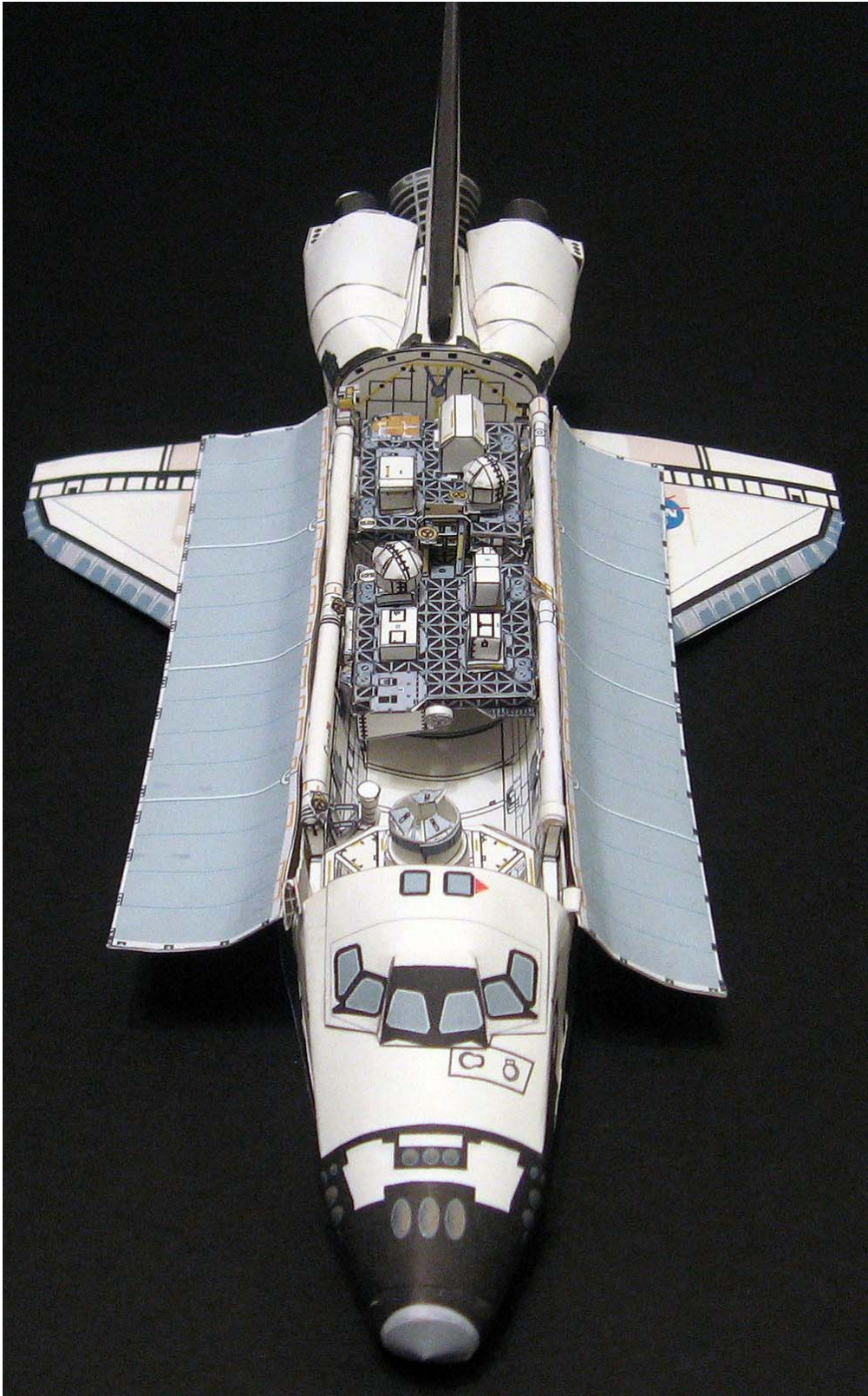

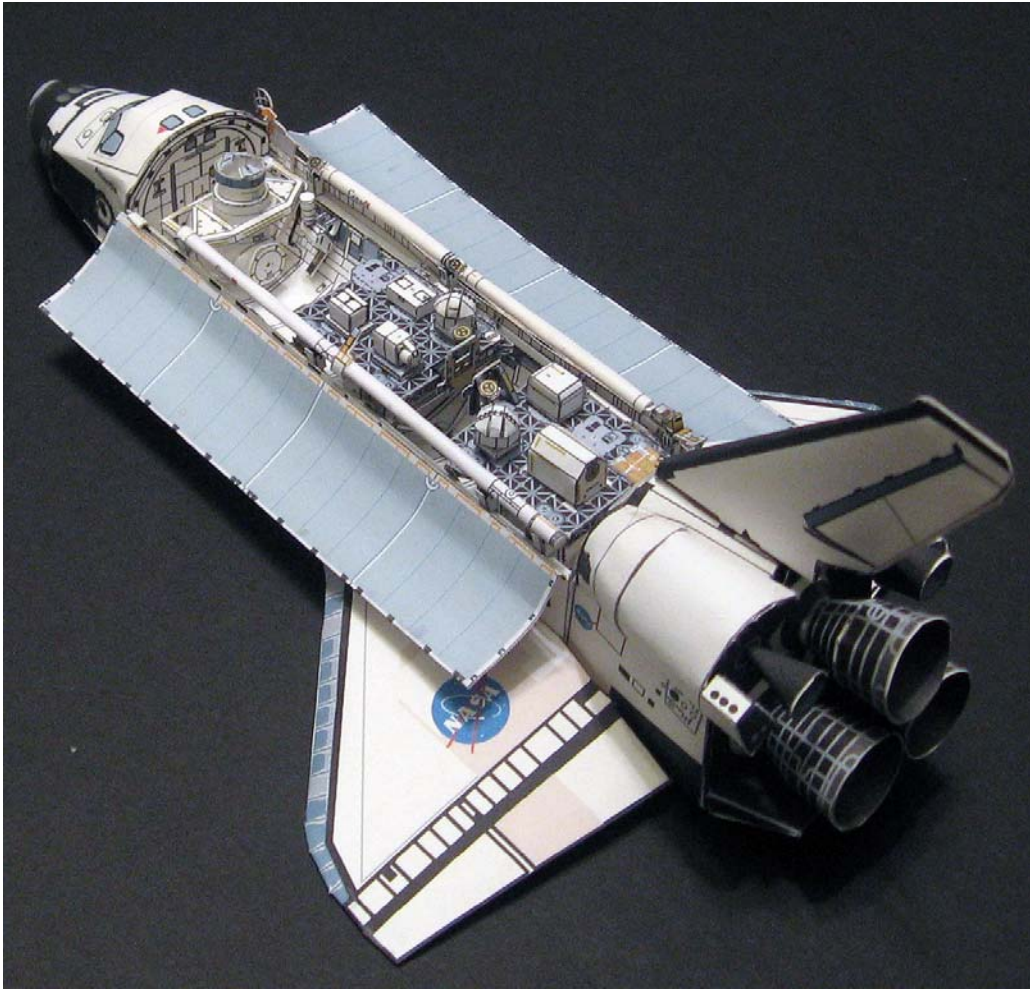

Enjoy this model!

www.axmpaperspacescalemodels.com