

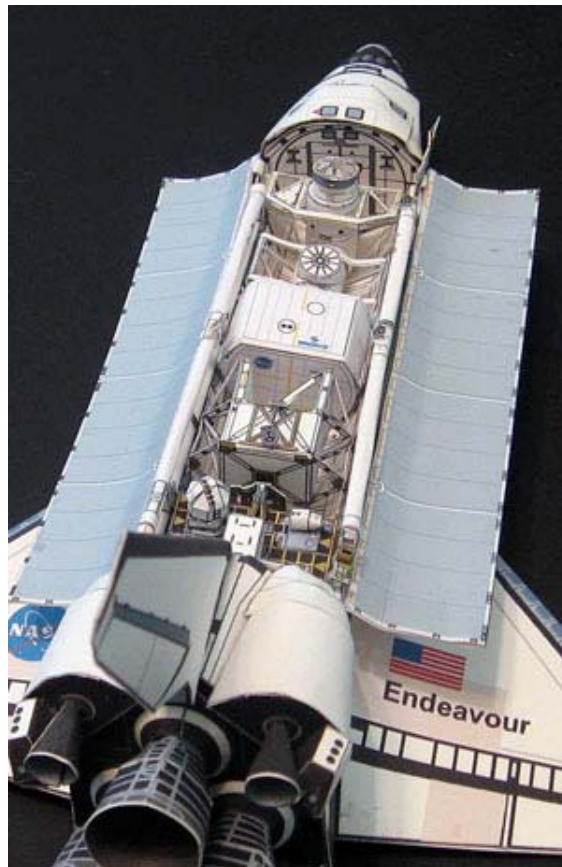

© 2010

Assembly Instructions for STS-118 payload (S5 truss and ESP-3)



Building the Orbiter Docking System

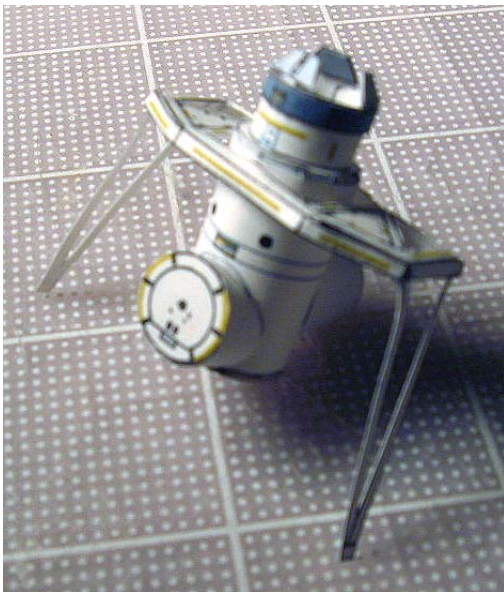

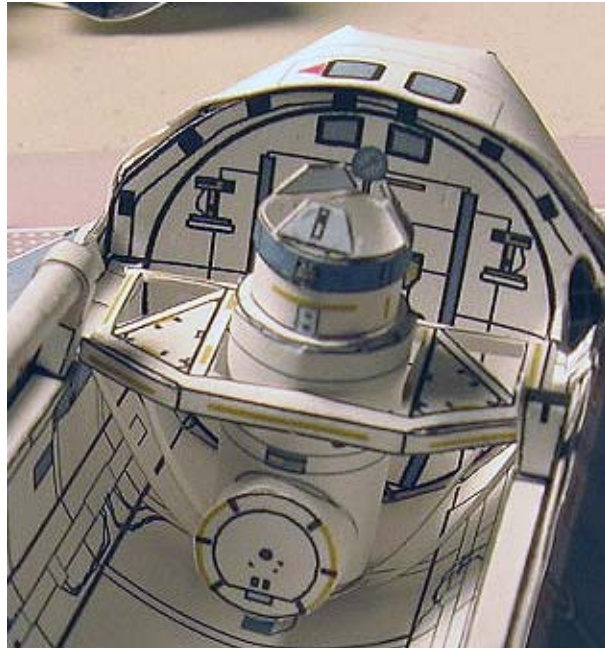
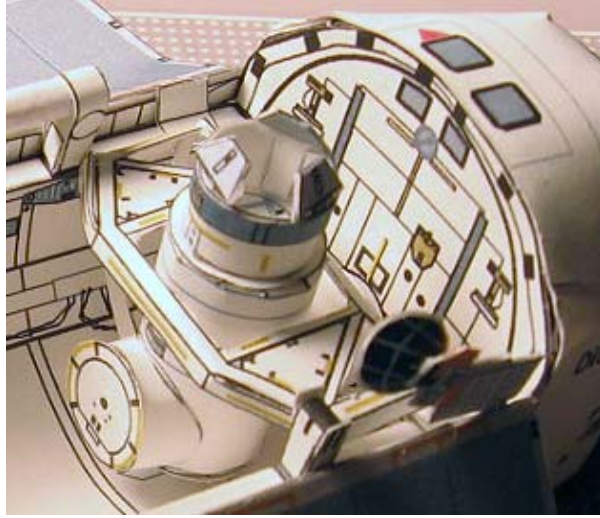

KU- band antenna



Note location of KU-band antenna that is glued on the tab from the right payload bay door.

For this manual, many photos from other mission kits were used. The Spacehab module photos shown here belong to STS-95 mission kit. Details might differ but is the same model.

Building the Spacehab Single Module.

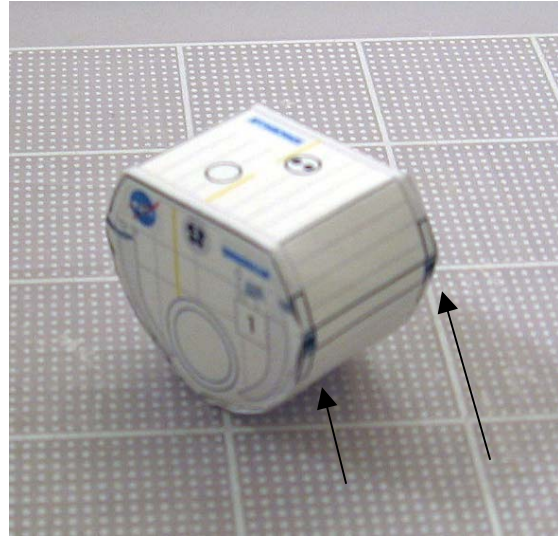
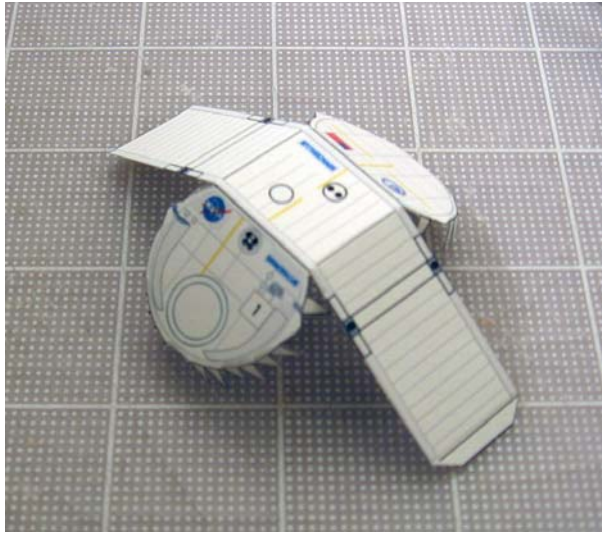

Glue the trunnions in each corner of the module.

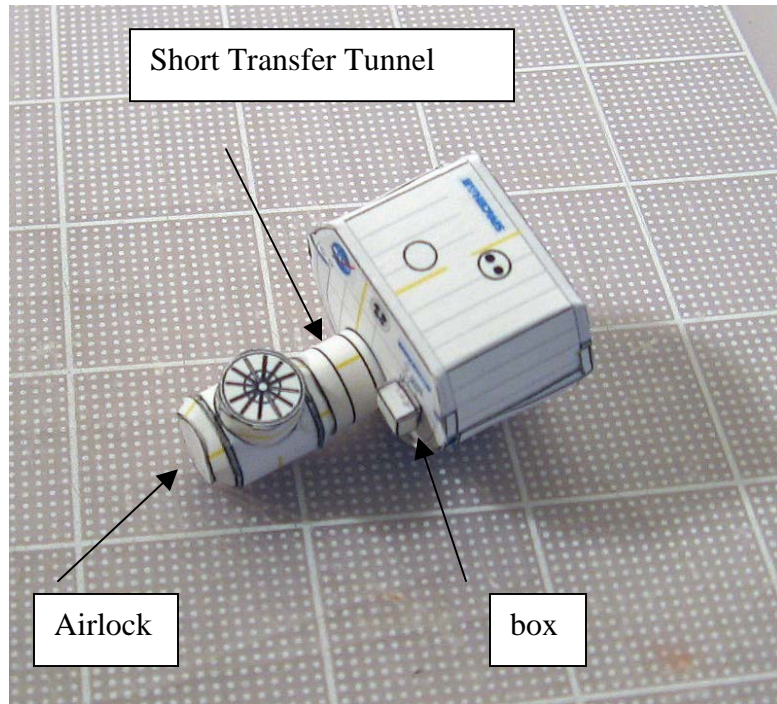

Transfer tunnel support assembly



Building the S5 truss

The S5 brought on this mission and the P5 from STS-116 are built the same way. Each segment truss is a copy of the other. The difference is the location on the ISS where they will be glued.

The P5 stands for Port side 5 truss, and the S5 stands for Starboard side 5 truss.

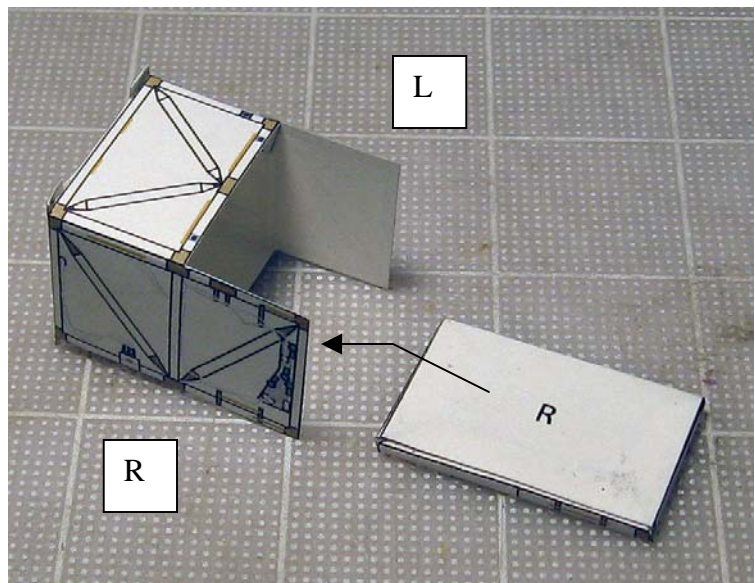
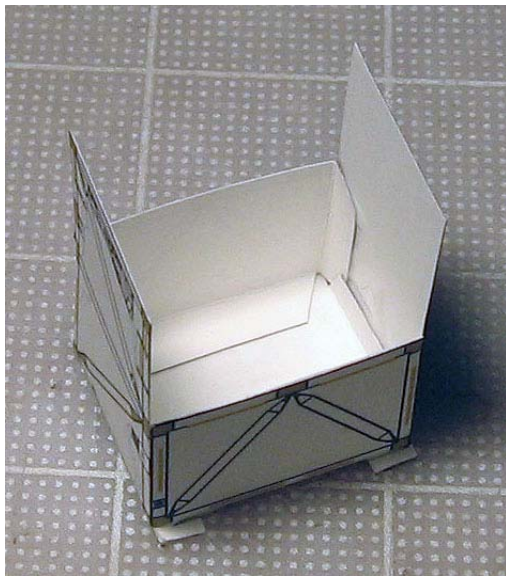
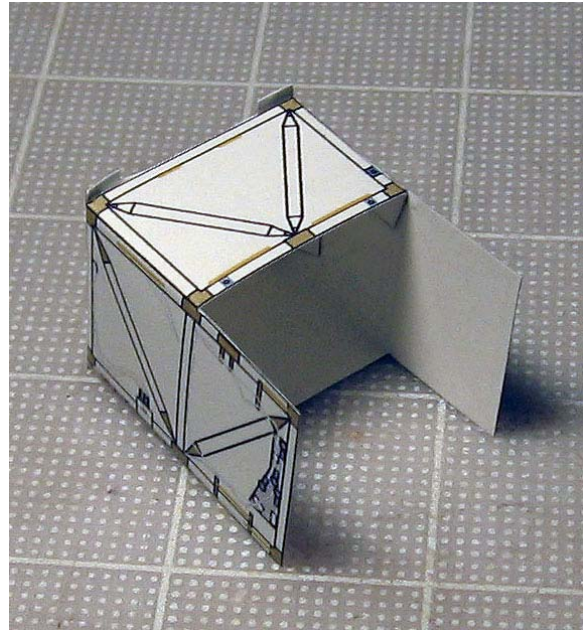
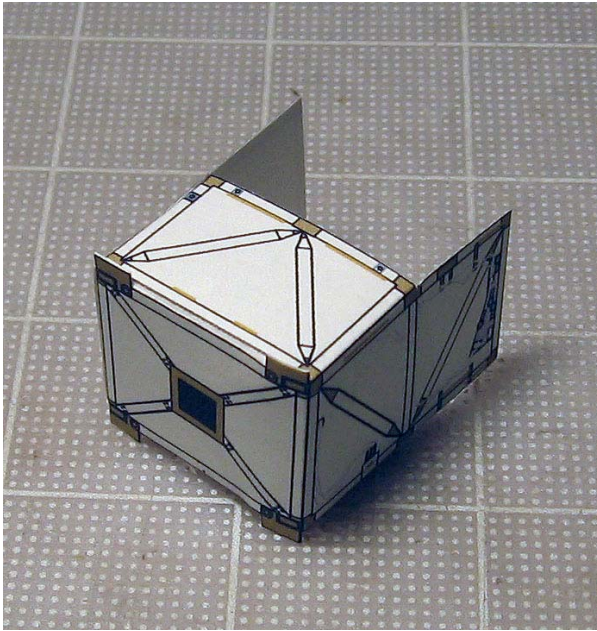

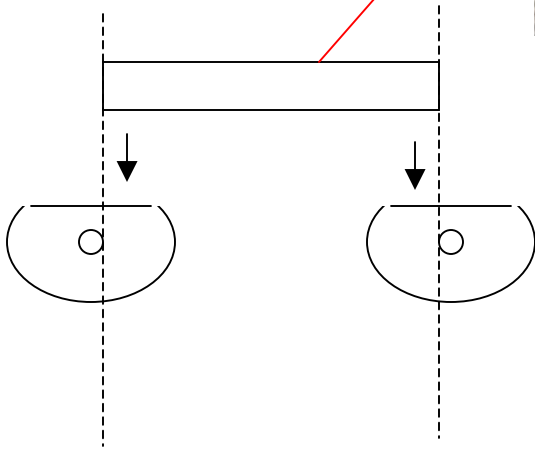
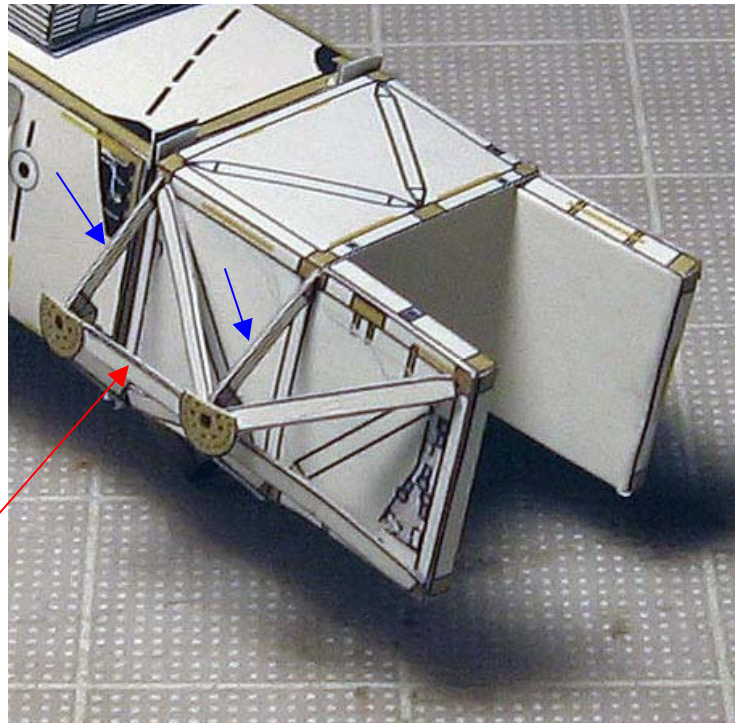
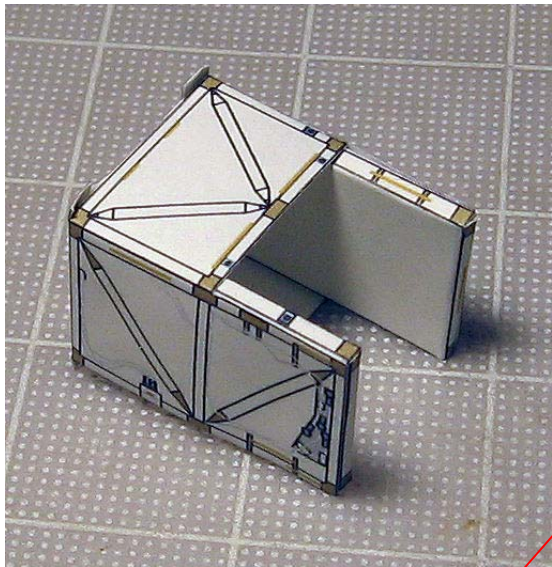
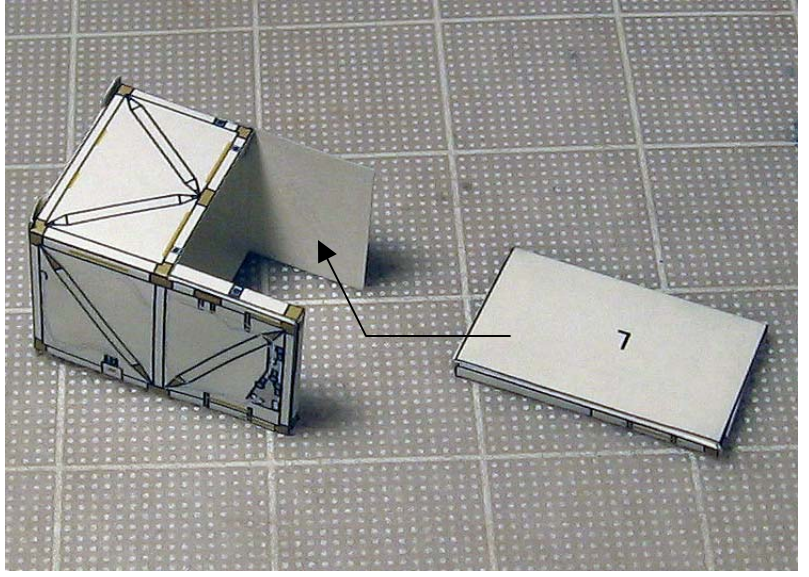
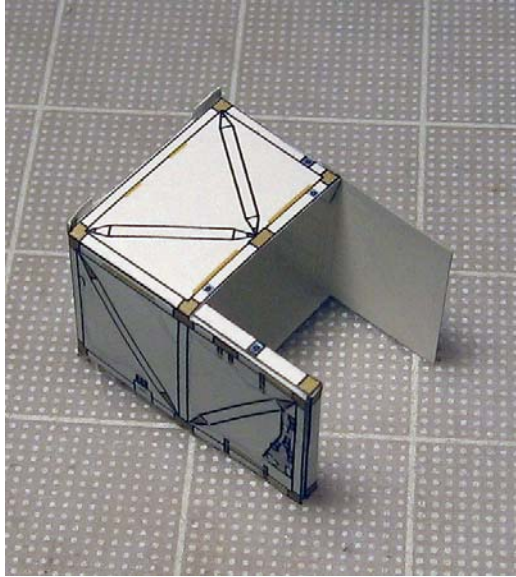

This diagram shows how the small horizontal bar (red arrow) is glued to the back of the half of each trunnion. Once the whole group is glued together, then everything is glued on top of each of the V shape parts on each side of the truss. (blue arrows)

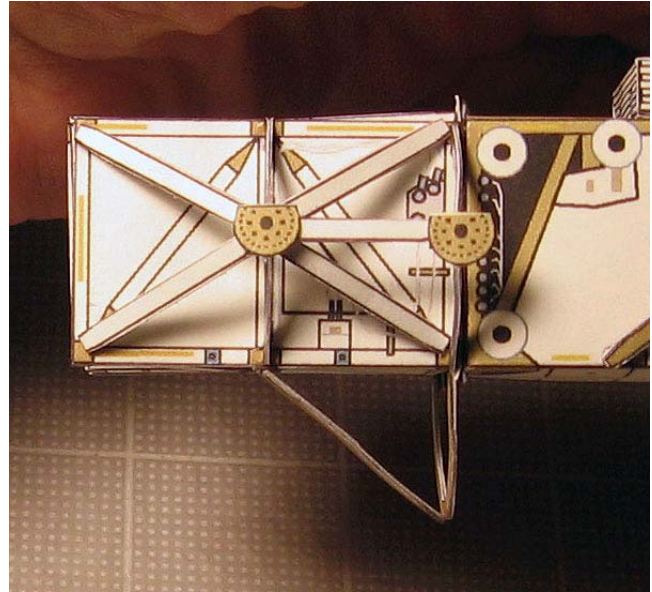
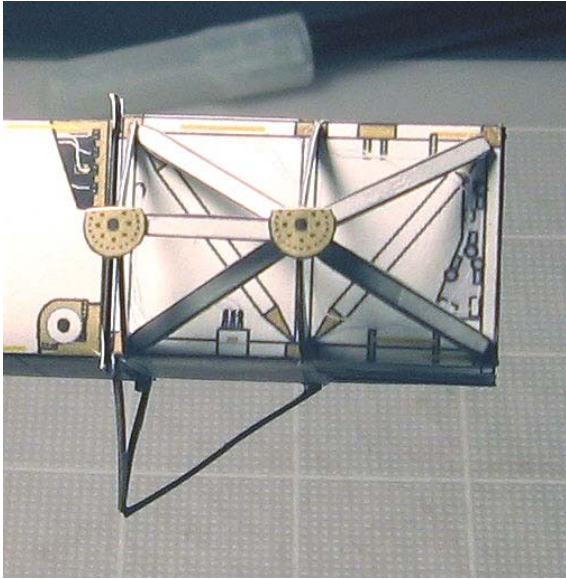

This presentation is obtained from the STS-116 mission kit. It's the same truss and the same assembly process.

These are views from both sides. Note details how and where the rest of the white beams are placed.

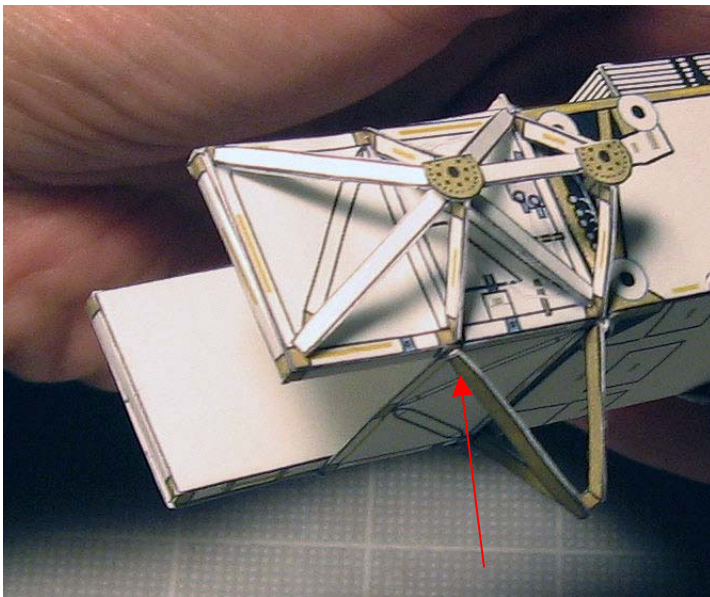

Note how the lower beam is glued to the left side of the truss.

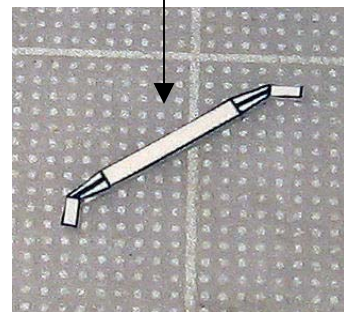
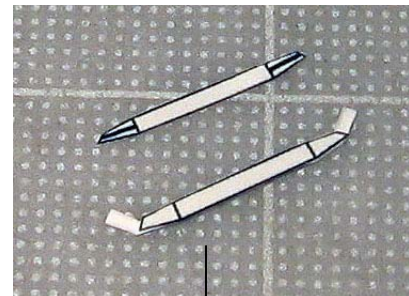

This beam goes on top and a similar one goes to the bottom of the truss.

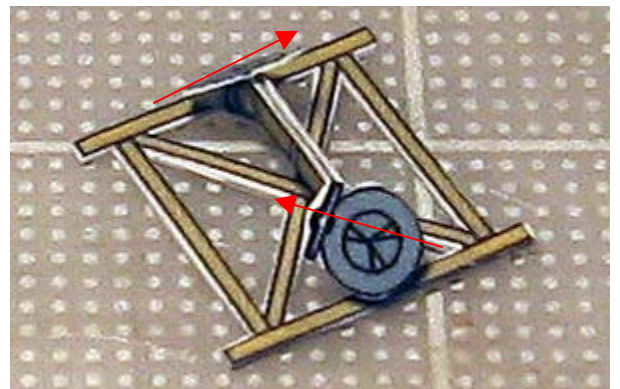
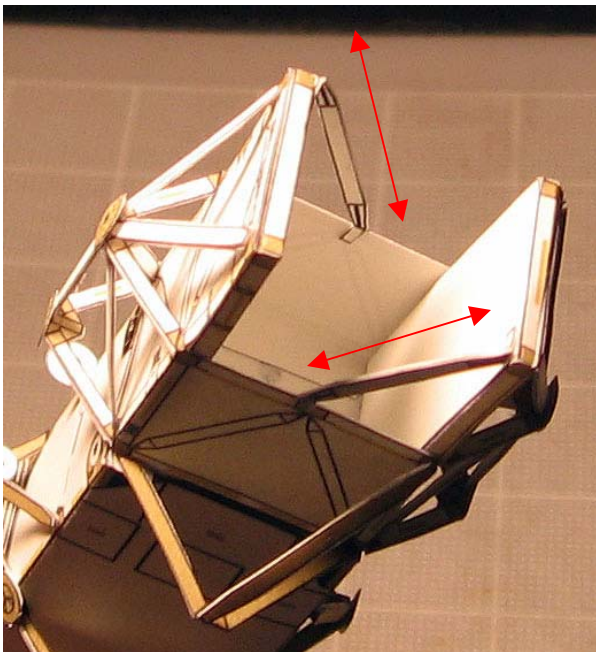
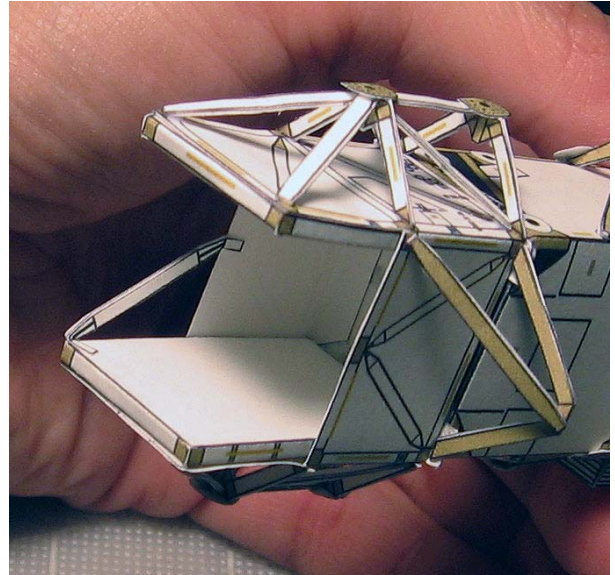
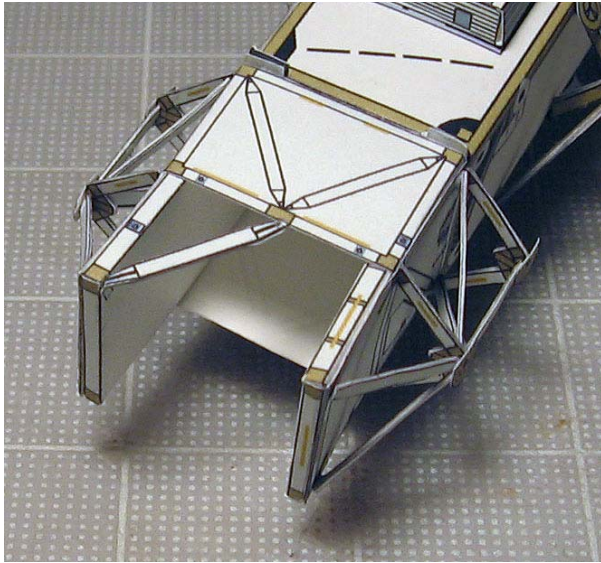

This is the PVRGF which has 2 grapple fixtures glued in opposite ways. (arrows)

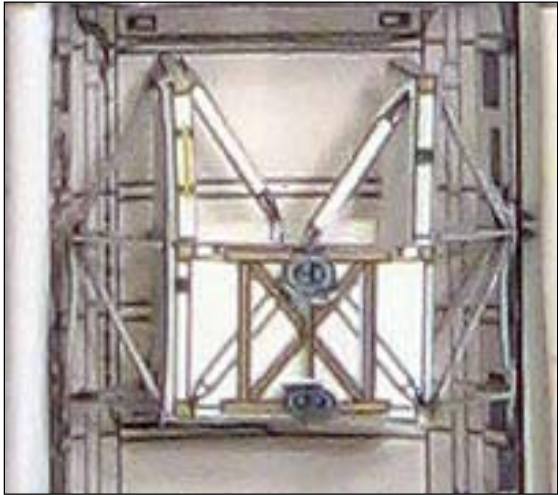

Note how the PVRGF is glued on top of the truss for payload bay configuration only.

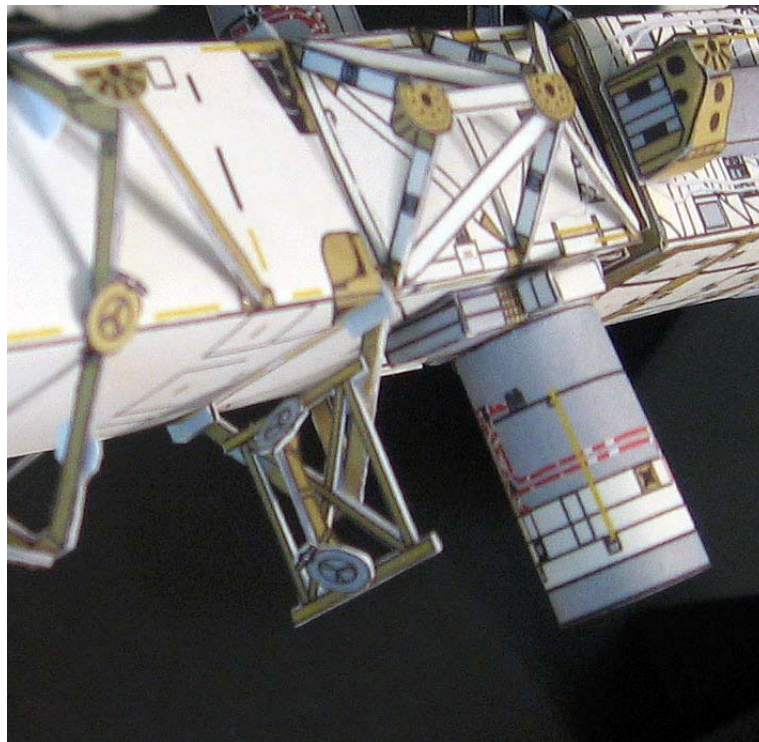

For Space Station configuration, the PVRGF is glued to the outer side of the V shape structure of the S5 truss, as shown on this photo.

Connecting the S5 to the rest of the Space Station

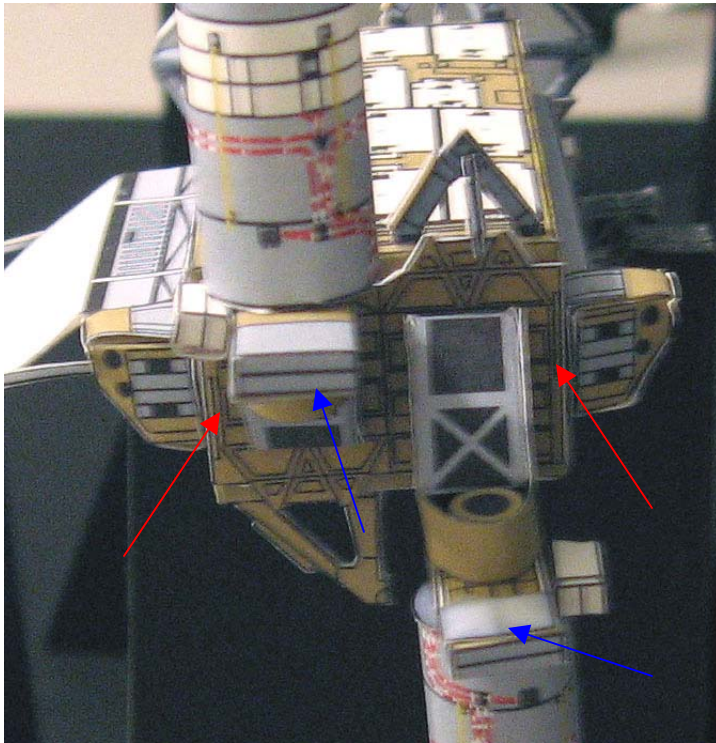

This is a view of the S4 segment truss (**STS-117 mission kit**). The arrows point to the areas where the S5 will be glued, on the sides to each of the solar panel canister supports.

The other areas that will hold tight the S5 truss is the upper and lower rectangular areas shown here with blue arrows.

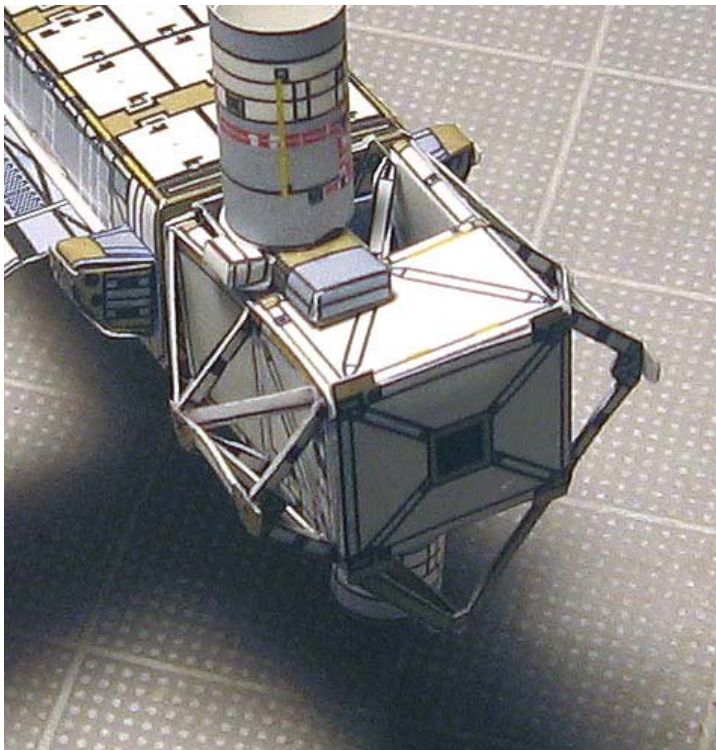

Note the details of this photo how both trusses are put together.

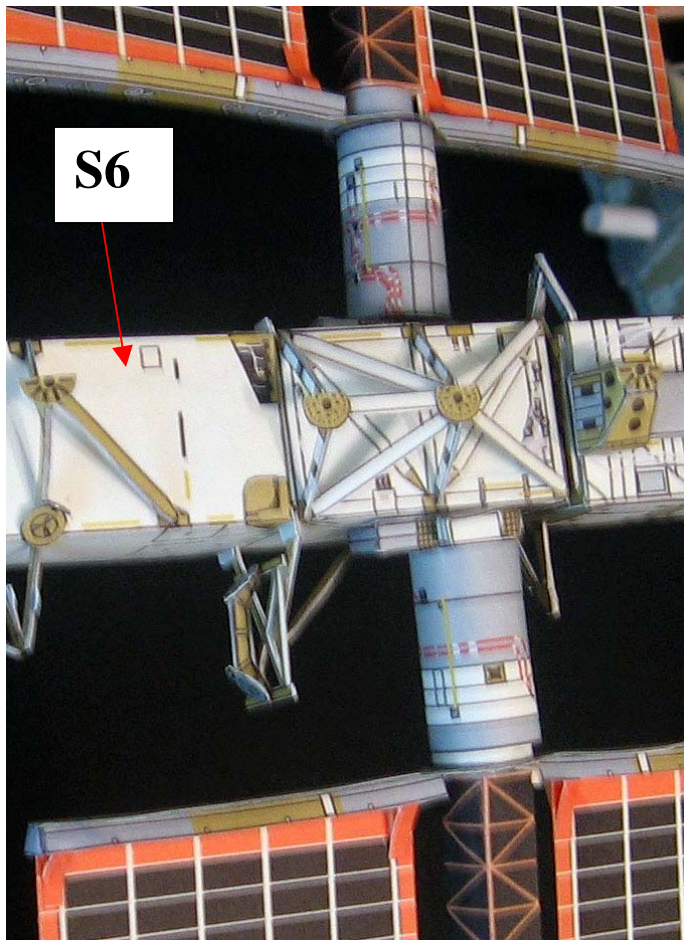
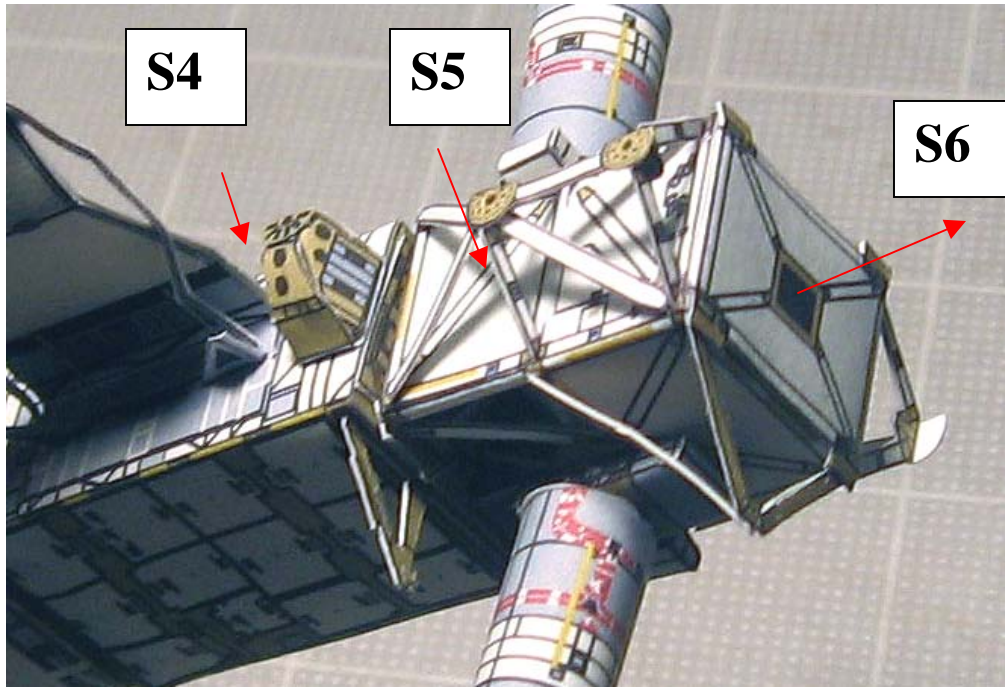

IMPORTANT TIP:

For better results, the best advice is to glue the S5 with the S6 together, AND THEN glue it to the end of the S4 -S3 truss.

External Stowage Platform 3 (ESP-3)

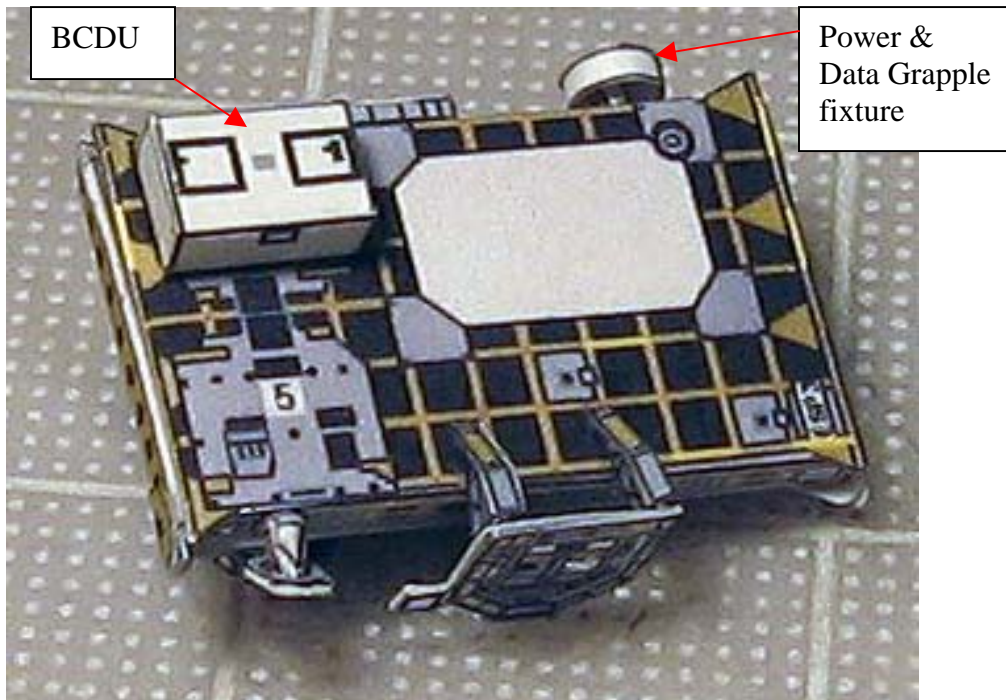
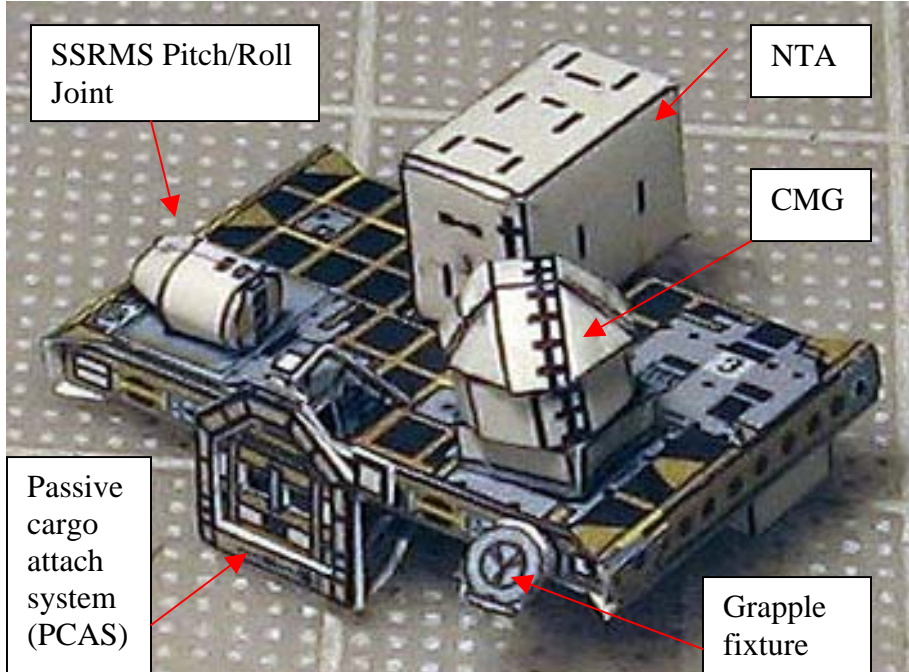

Building the Passive Cargo Attach System for ESP-3

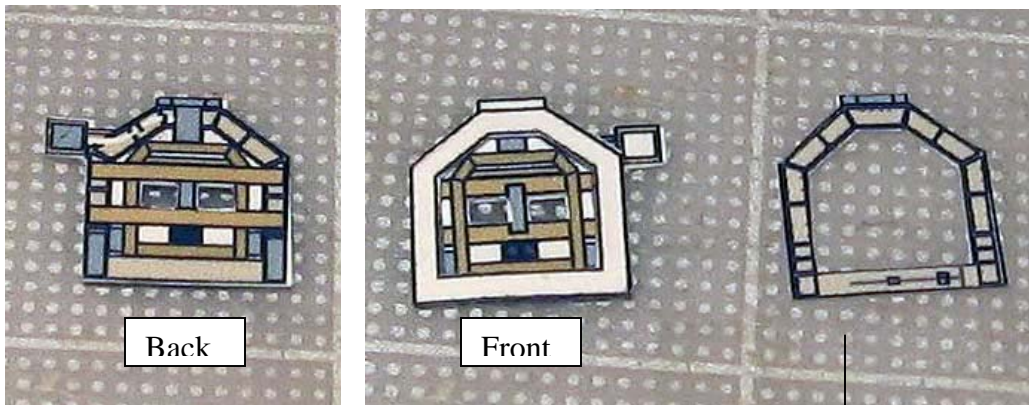

These are the parts for the PCAS. Glue back and front sides and continue gluing other similar parts to make this element thicker depending if it's 1:144 or 1:100 scale versions.

The red arrows show where to cut out the small windows. **This is where the "claw" from the UCCAS on the P3 truss element (STS-115 mission kit) will attach.**

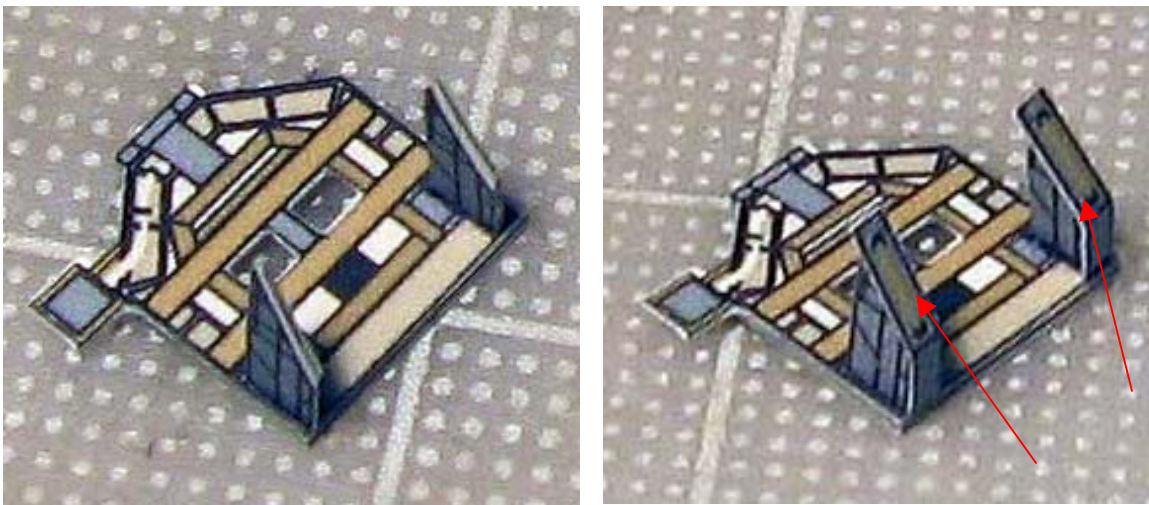
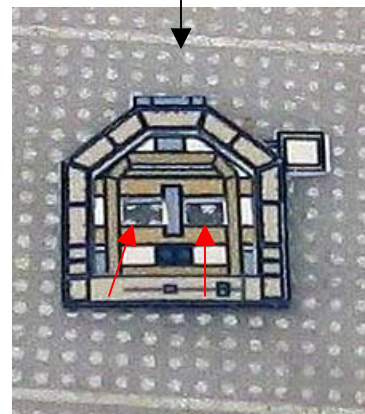

Glue the lower supports at each lower corner on the backside and then cover each edge with small rectangular parts (arrows).

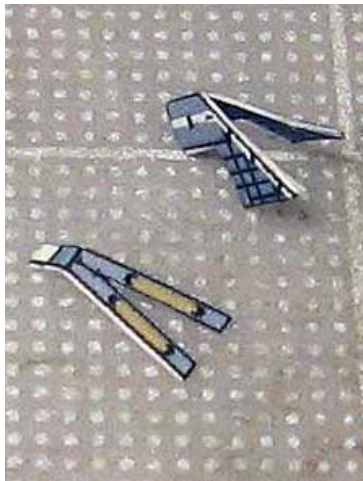
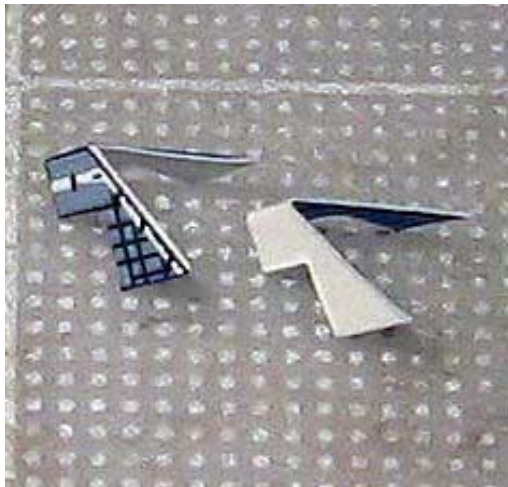

These are the steps to build the upper support for the ESP-3

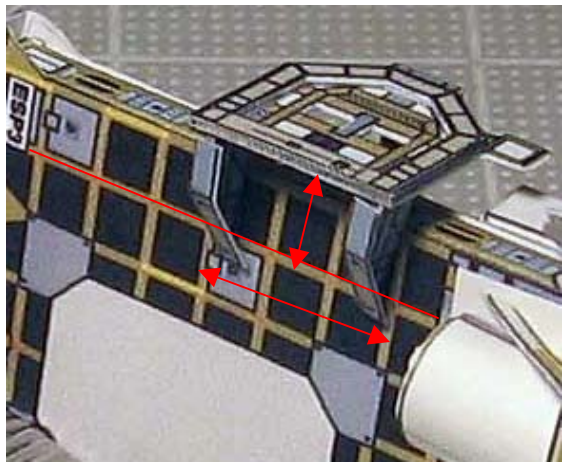
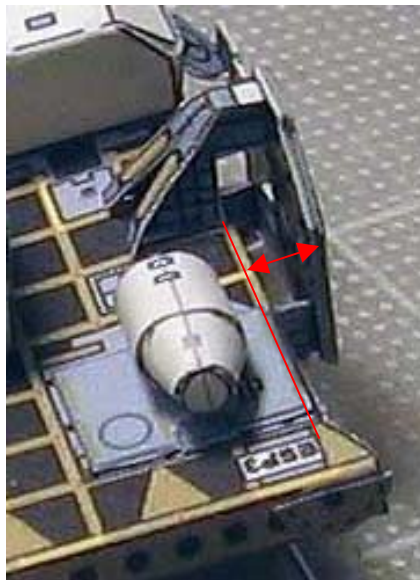
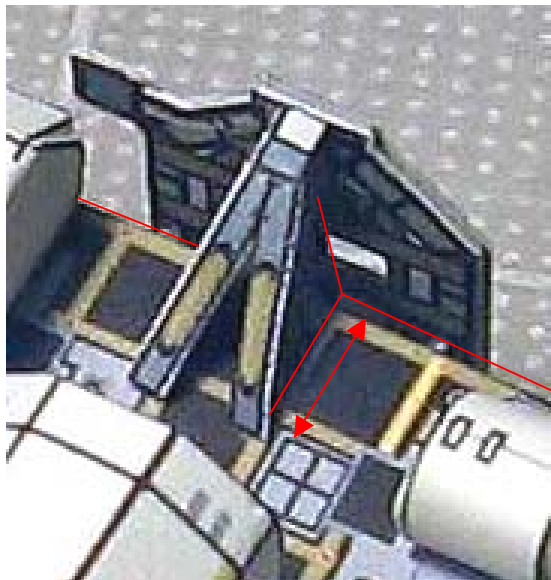

Note the details on these photos in order to glue this part to the ESP-3.

Building the Control Moment Gyro (CMG)

The CMG is an original element for this first ESP-3 configuration during launch on the payload bay only, but not for the space station version. The CMG was relocated to the ESP-2 during an EVA on this mission.

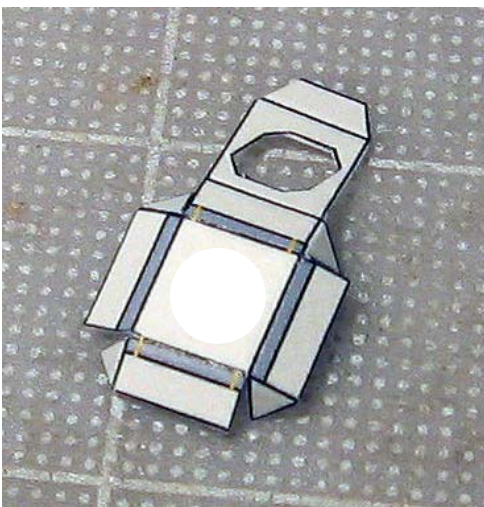
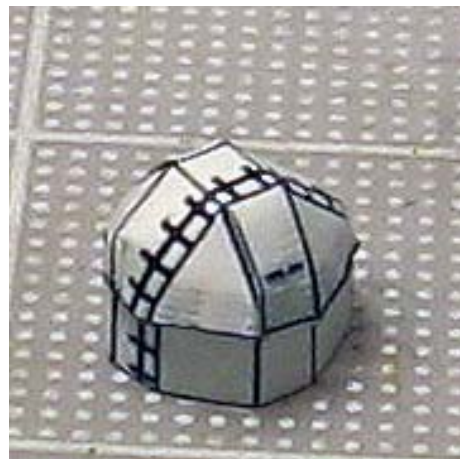
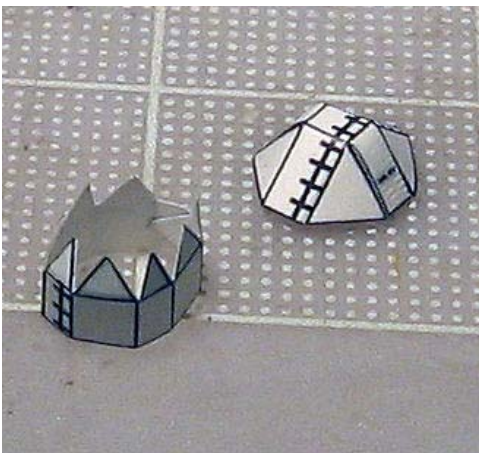
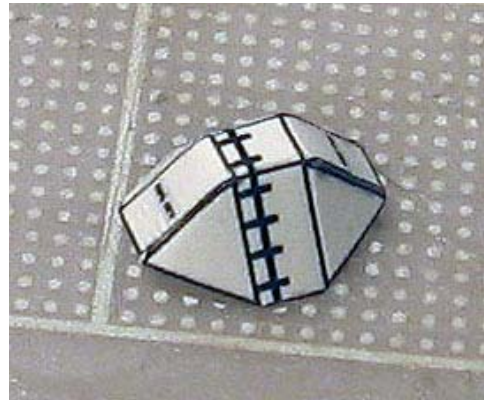
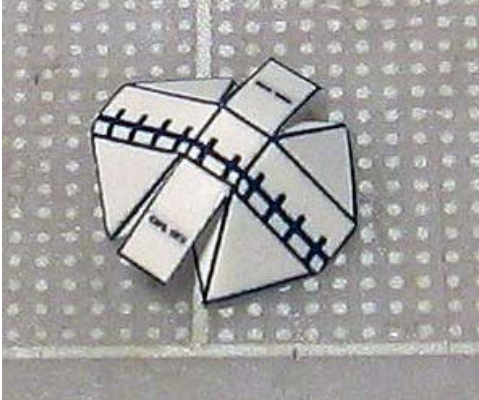

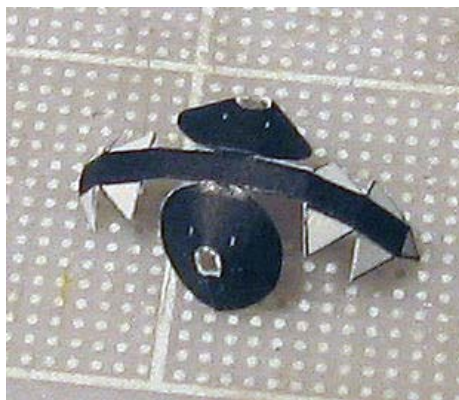
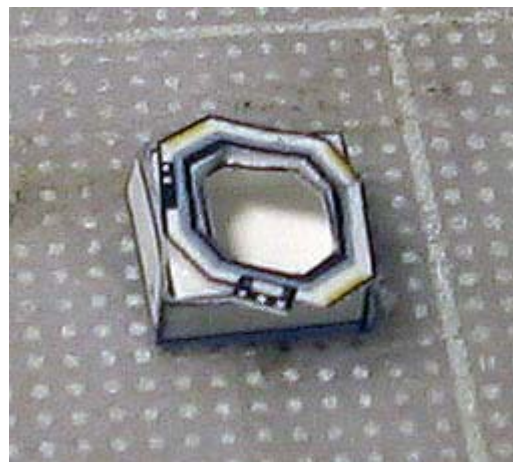
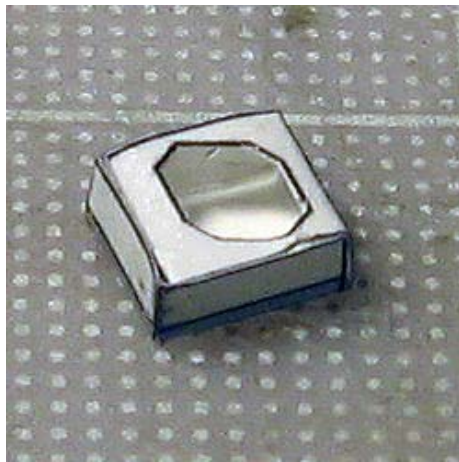

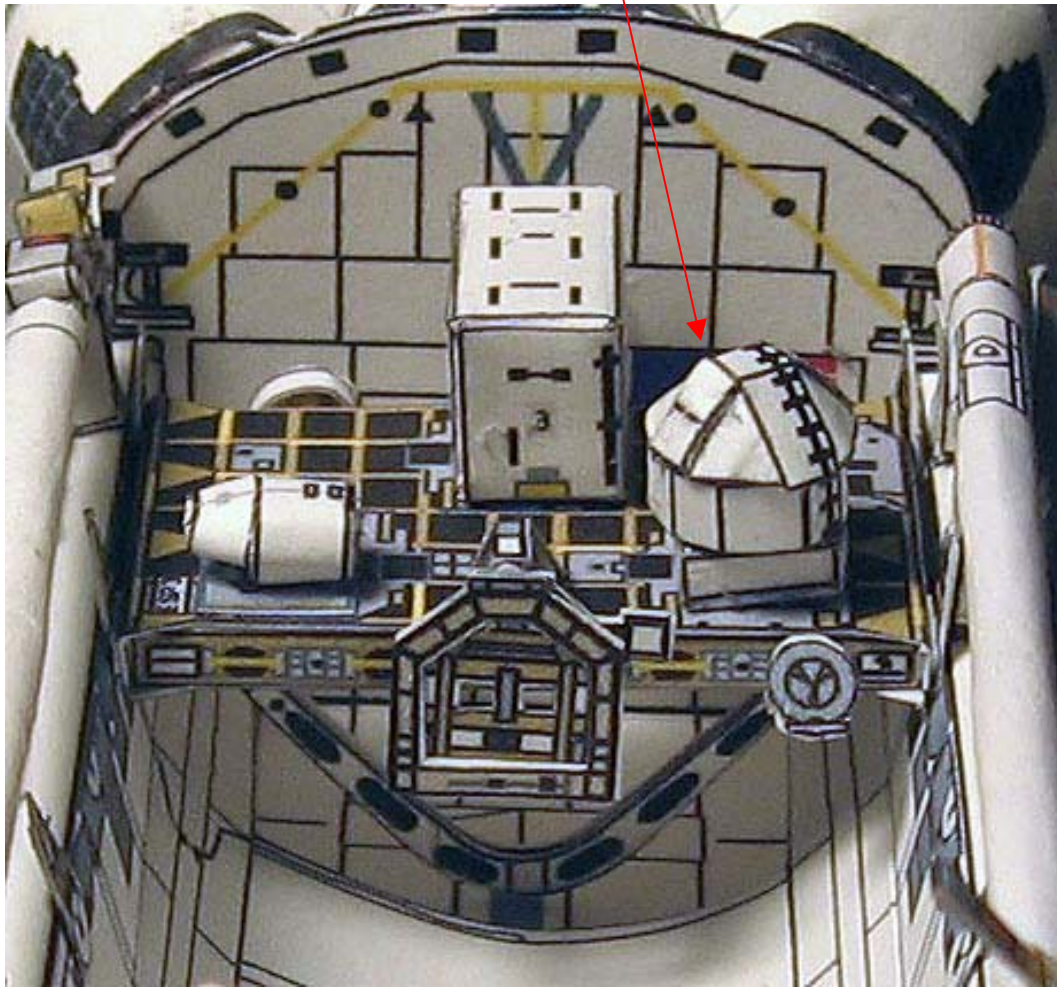
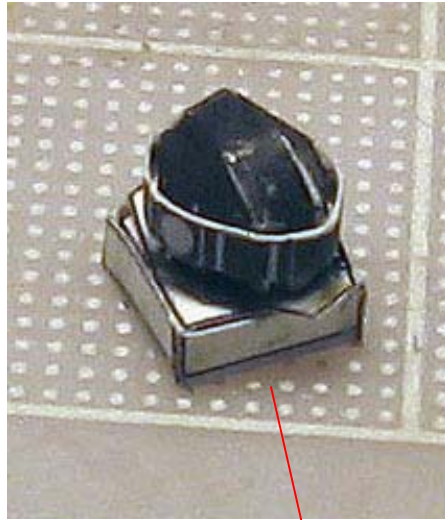

Connecting ESP-3 to the ISS

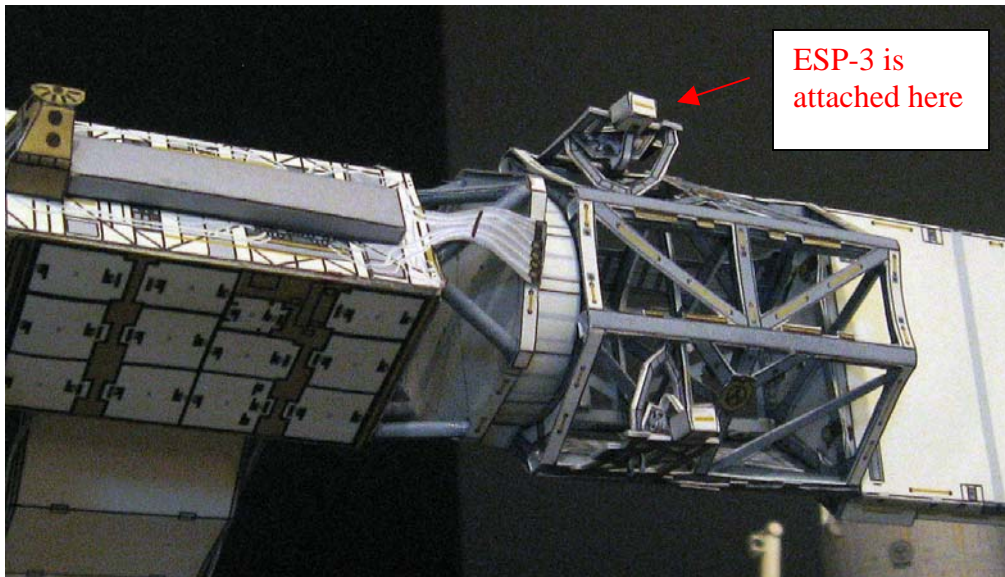

This is an aft view of the P3-P4 truss from STS-115 mission kit. This truss has 2 UCCAS (top and bottom). The top (zenith) UCCAS is the attachment location for the ESP-3.

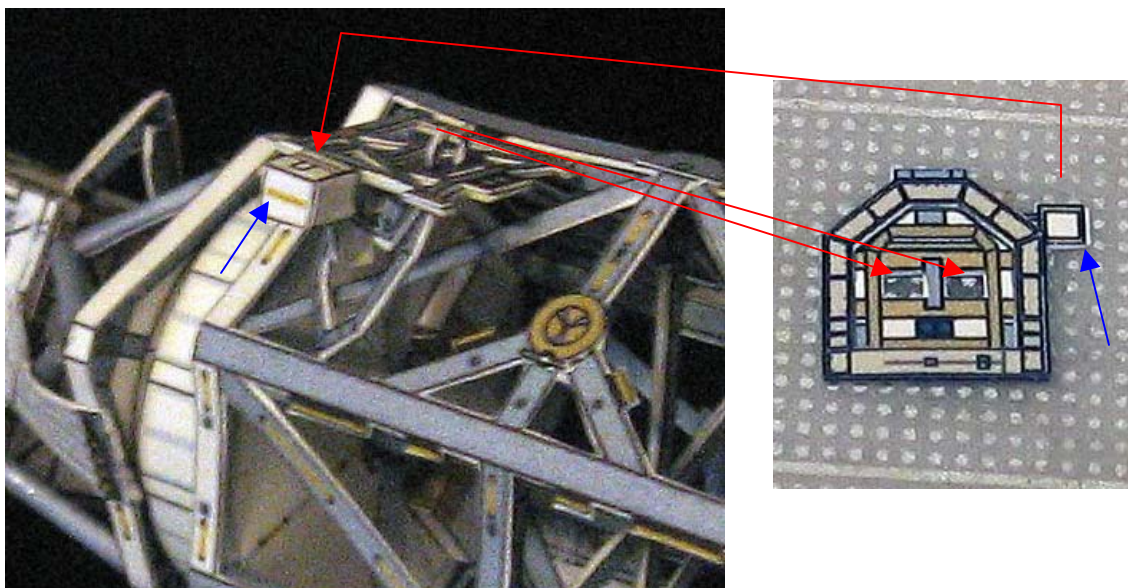

When the ESP-3 is placed on top of the P3, both boxes (blue arrows) need to match one on top of the other, and the "claw" will insert into the windows of the PCAS holding it tight. **DO NOT GLUE THE ESP-3 TO THE P3 BECAUSE IT WILL BE MOVED LATER TO ANOTHER LOCATION**

Reference Photos

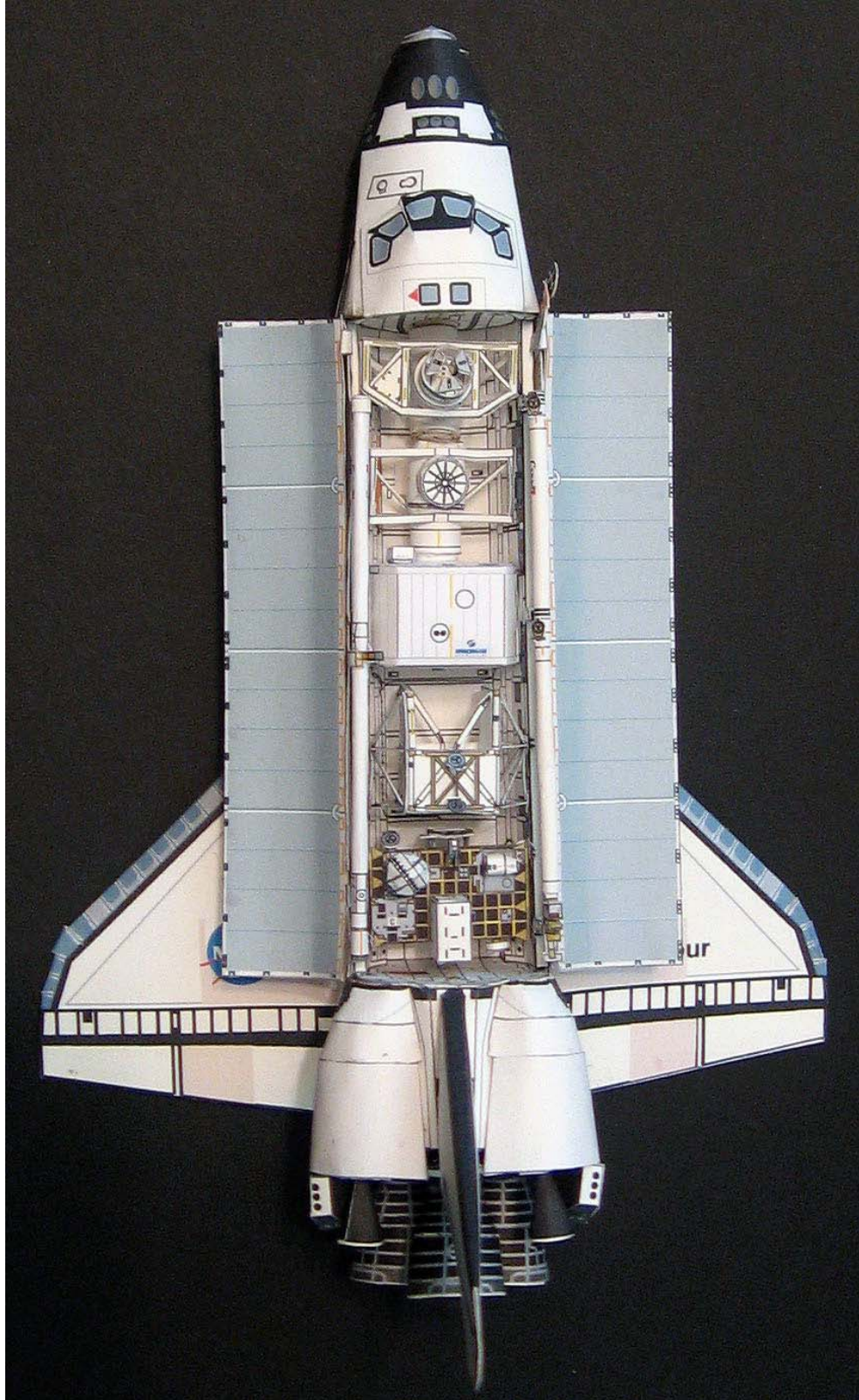

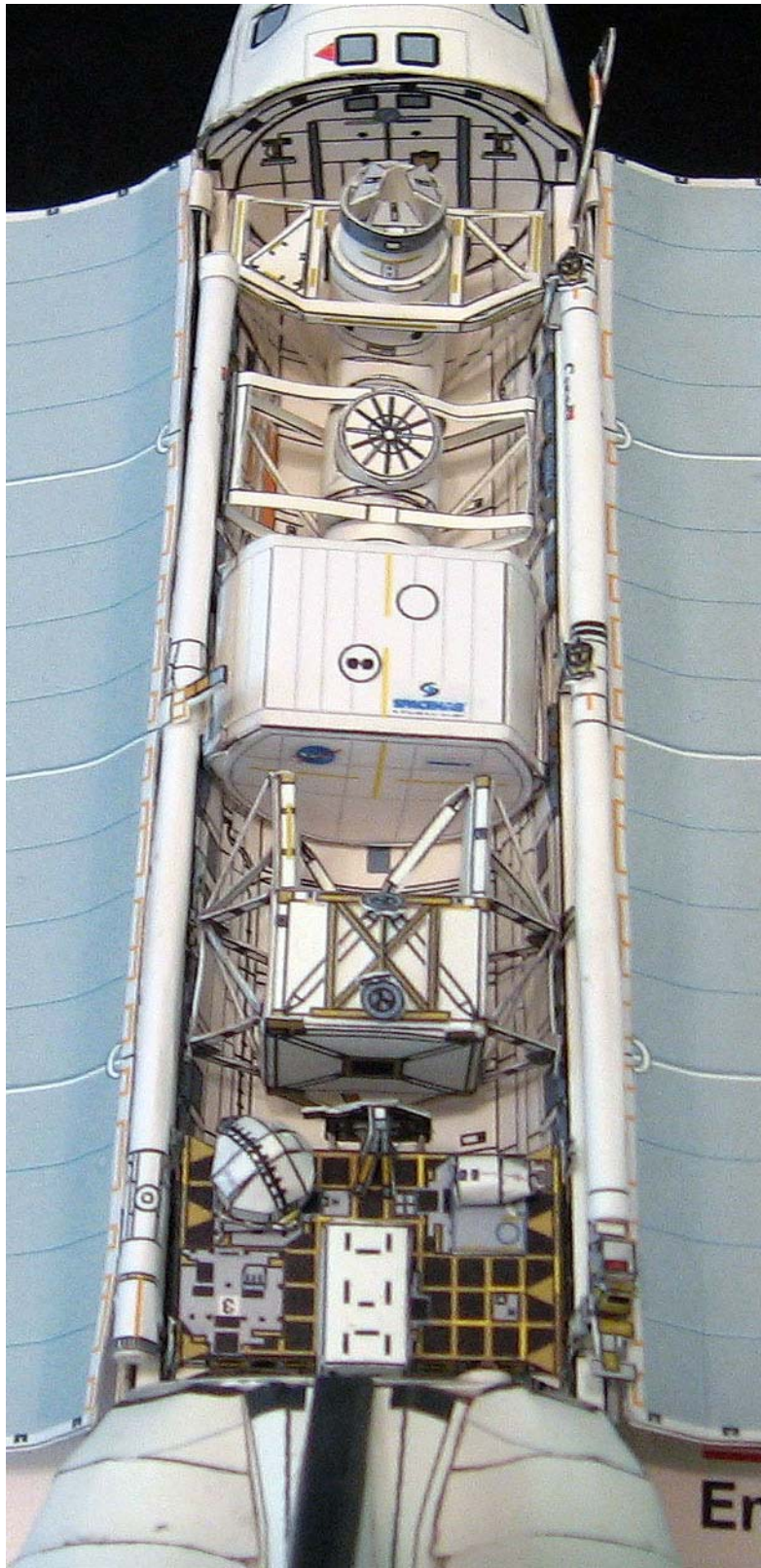

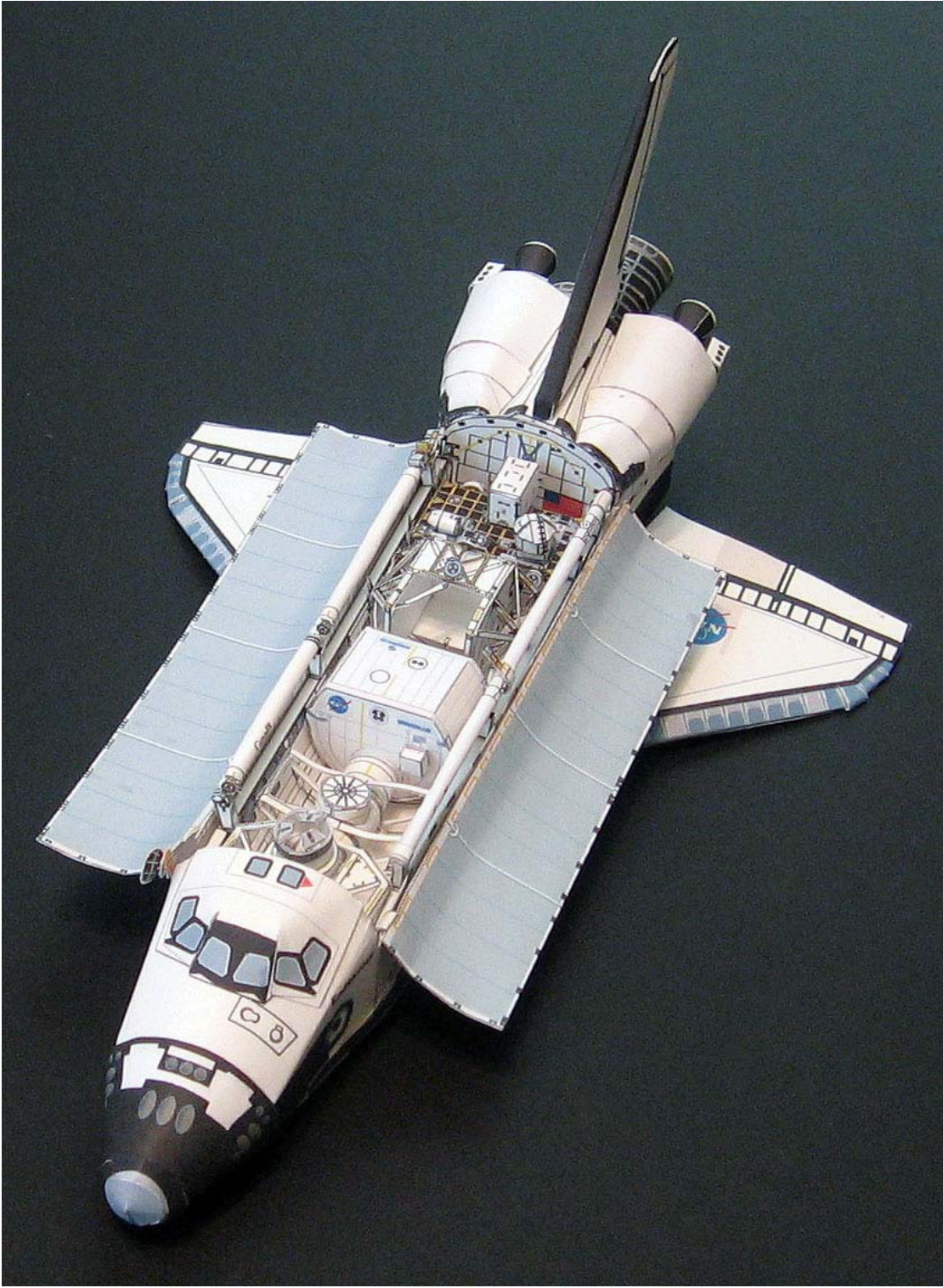

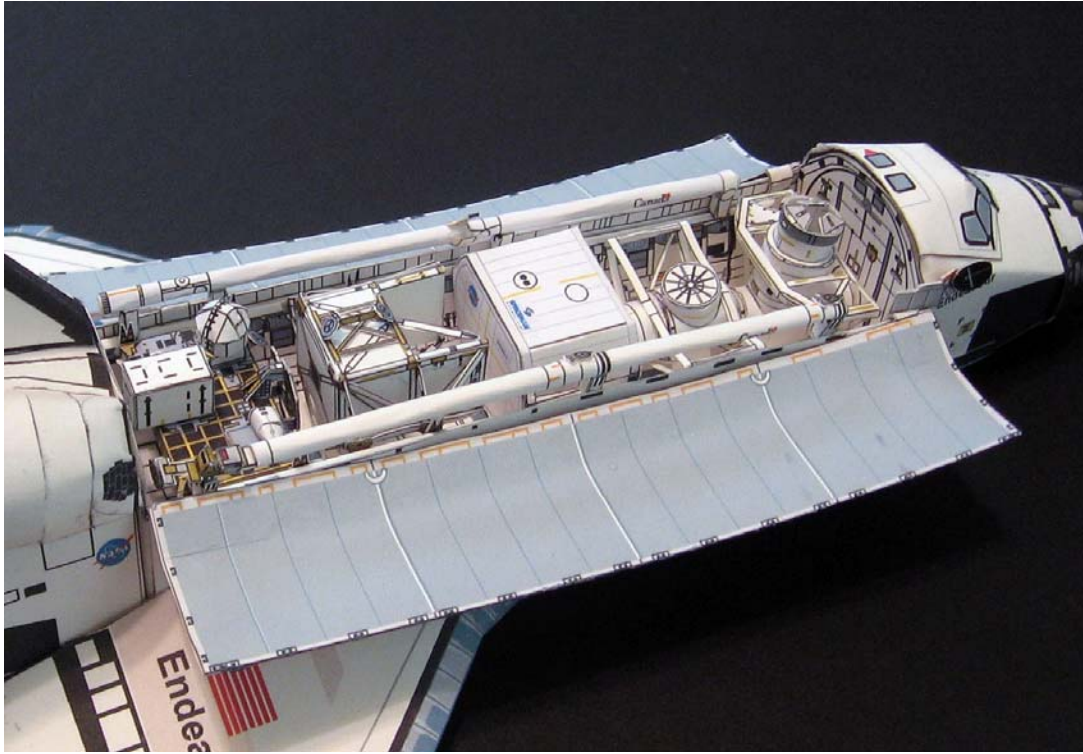

Enjoy this model!

www.axmpaperspacescalemodels.com