

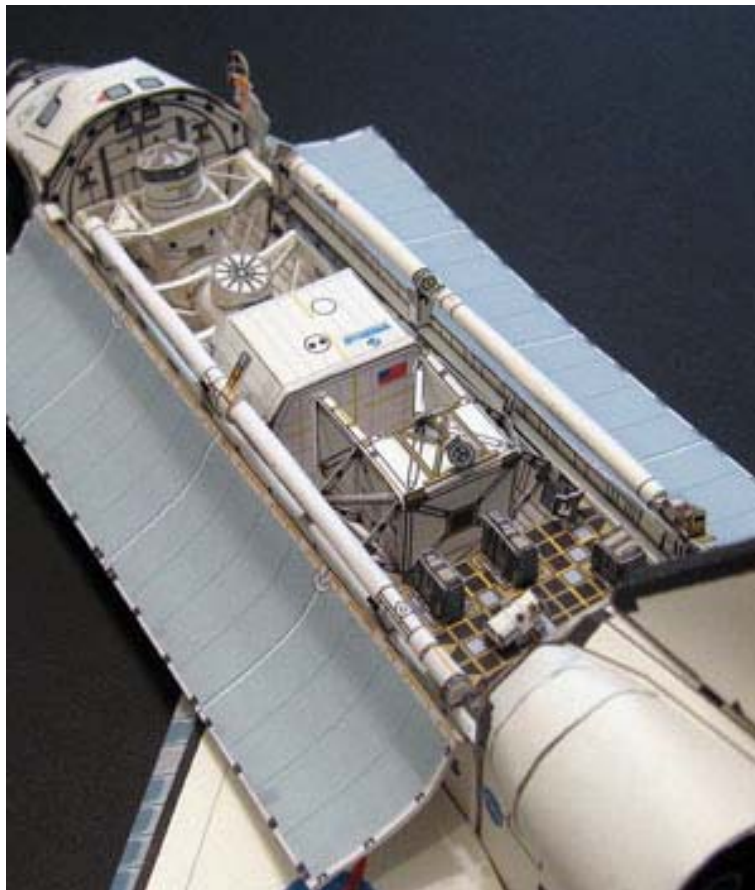

© 2010

## Assembly Instructions for STS-116 payload (P5 truss)



## Building the Orbiter Docking System

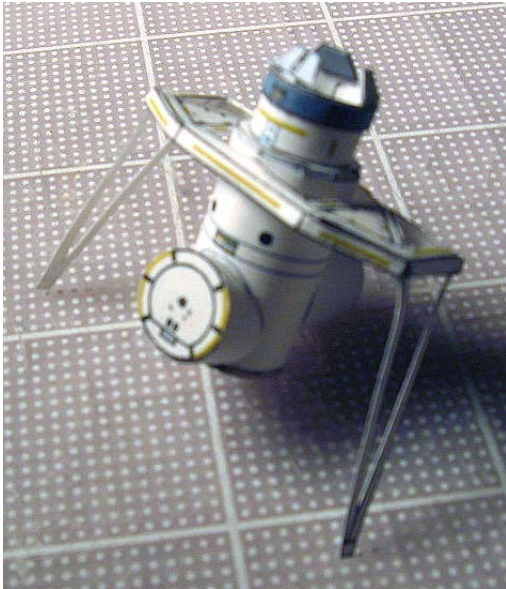

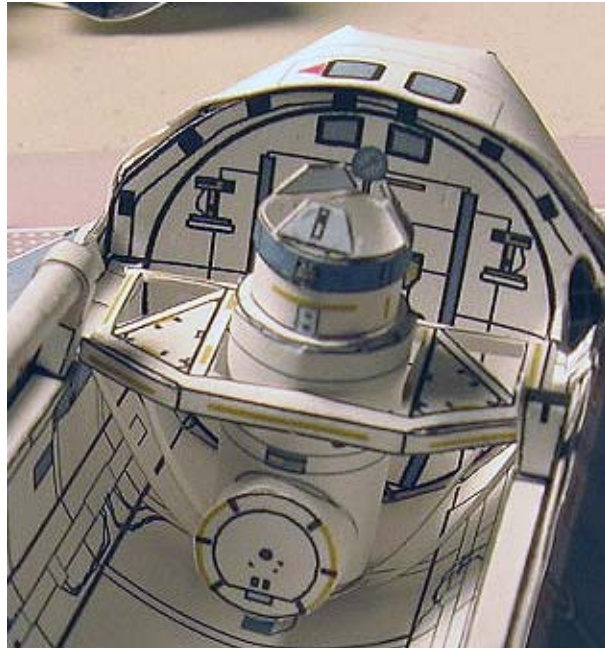

**KU- band antenna**



Note location of KU-band antenna that is glued on the tab from the right payload bay door.

For this manual, many photos from other mission kits were used. The Spacehab module photos shown here belong to STS-95 mission kit. Details might differ but is the same model.

### Building the Spacehab Single Module.

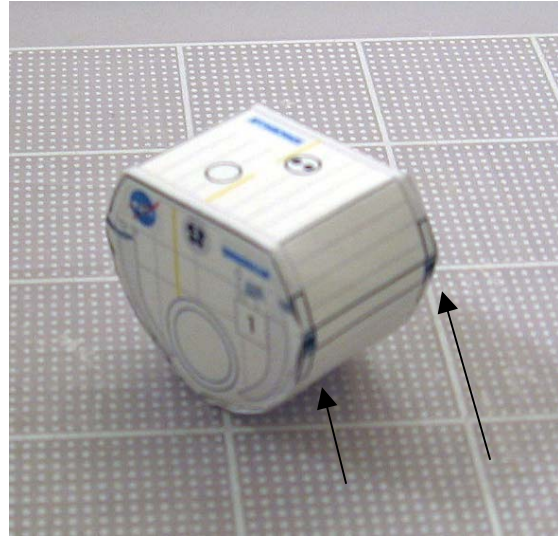
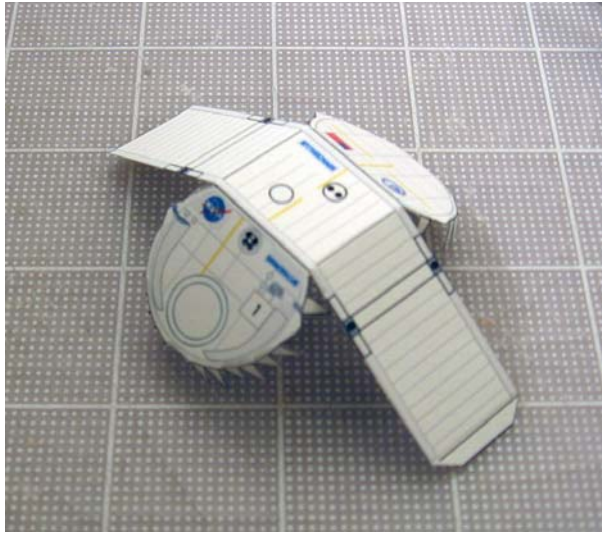

Glue the trunnions in each corner of the module.

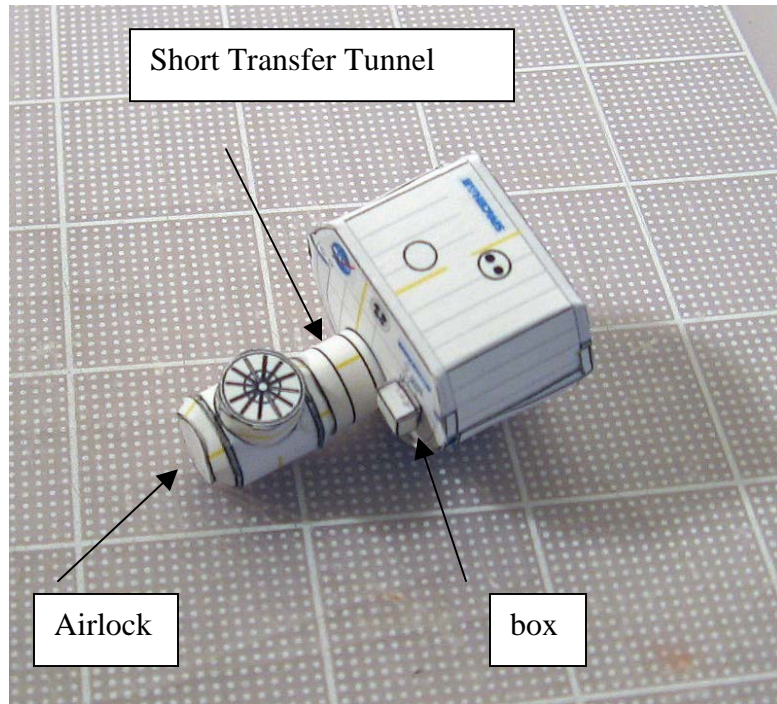

## Transfer tunnel support assembly



## Building the Integrated Cargo Carrier (ICC)

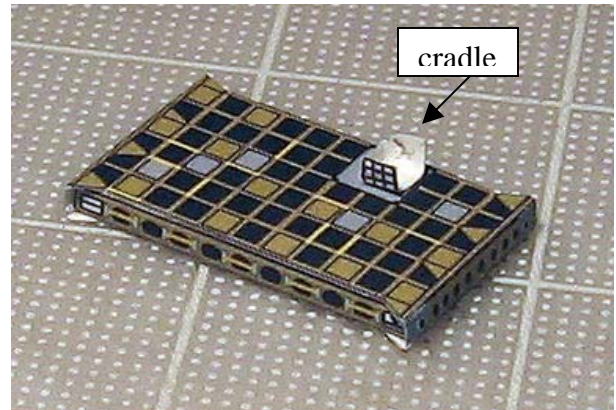
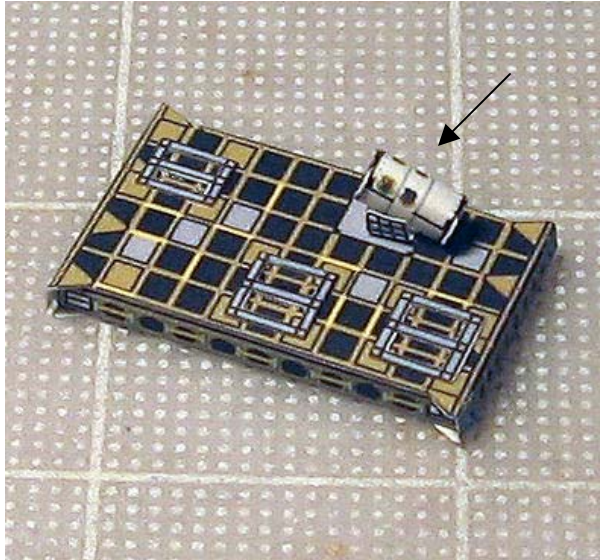

The white cylinder is the STP-H2 launcher. It's a plain cylinder glued to its cradle.

The ICC carried the 3 Service Module Debris Panel packages (SMDP). Each package is built as a box as this photo shows. Match the numbers and glue.

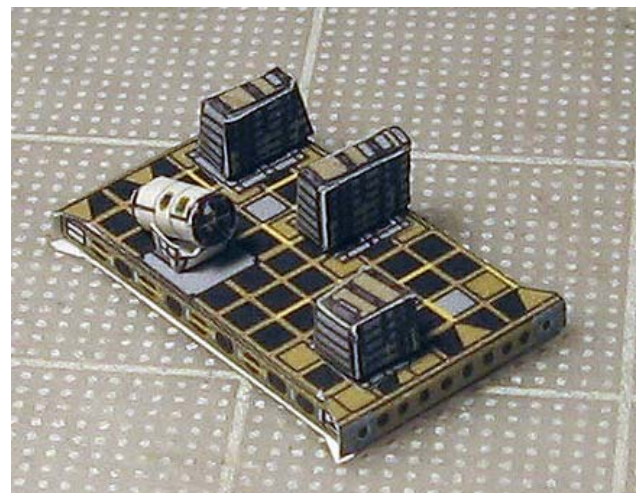
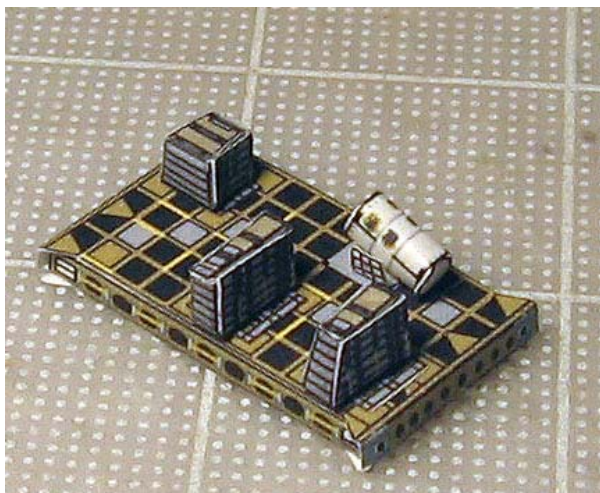

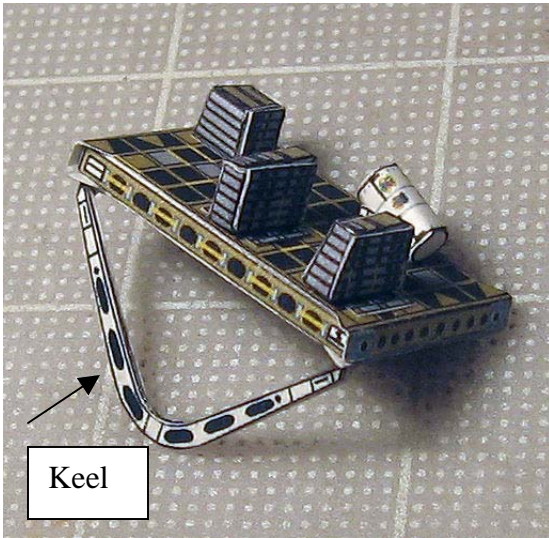

Keel

The payload bay keel is glued to the bottom of the ICC on the front corners.

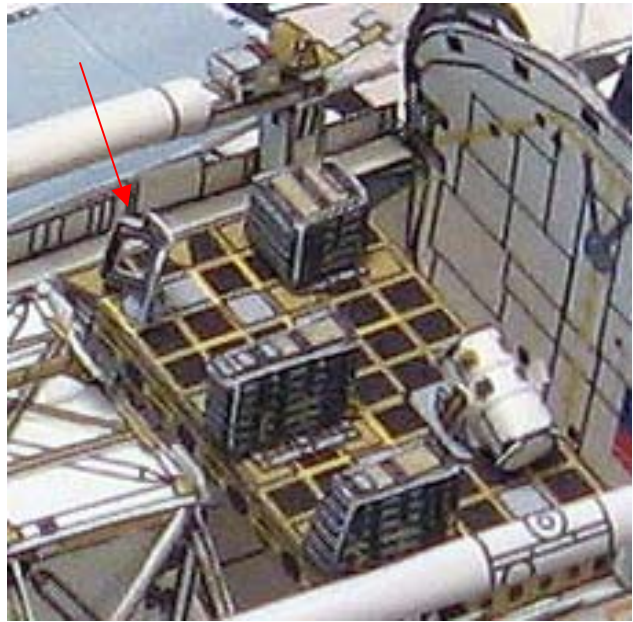

The last piece to glue on the ICC is the SMDP adapter. It consists of 2 parts glued back to back and placed on top of a circle. (arrow)

**Preview of the Service Module Debris Panels (only for the 1:100 scale ISS model)**

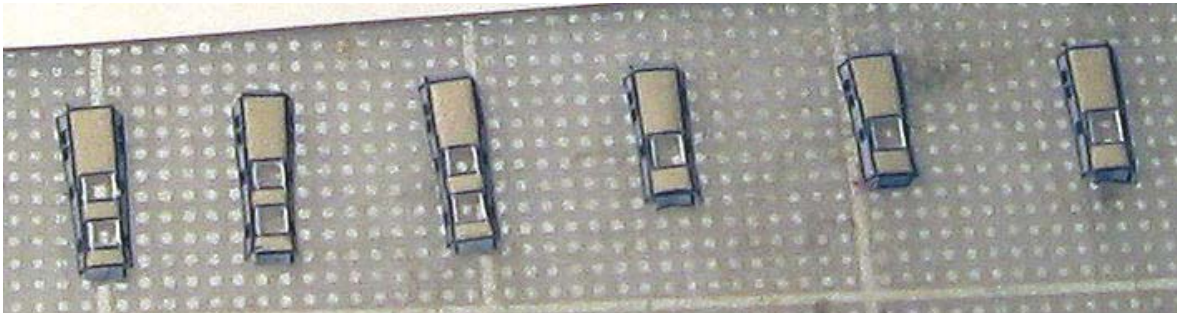

The SMDP's are placed on the larger diameter cone of the Zvezda Russian module (will be released in the future). Follow the SMDP layout available in the STS-116 mission file in order to correctly glue each panel on Zvezda. The 1:144 scale version is a more simple approach. The panels are glued as a whole around the larger diameter cone of the Zvezda model.

## Building the P5 truss

The P5 brought on this mission and the S5 from STS-118 are built the same way. Each segment truss is a copy of the other. The difference is the location on the ISS where they will be glued.

The P5 stands for Port side 5 truss, and the S5 stands for Starboard side 5 truss.

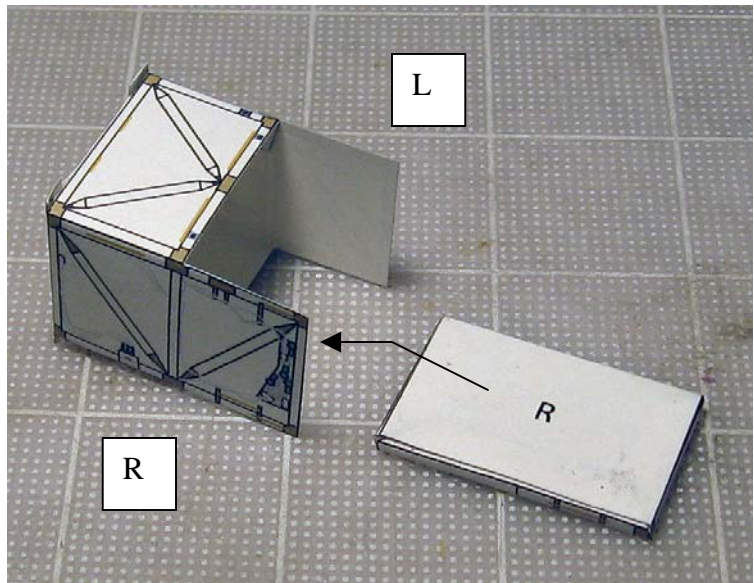
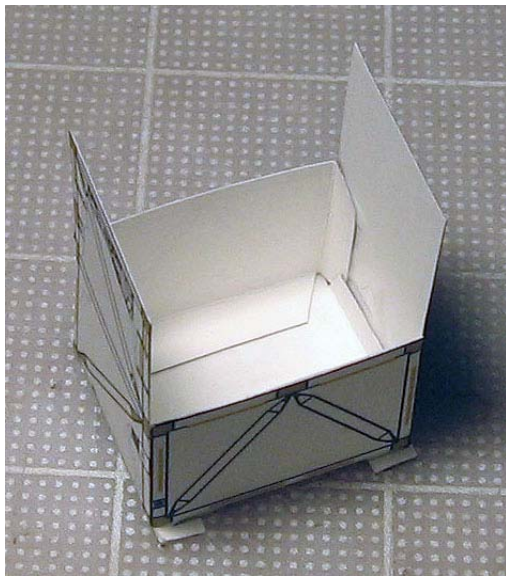
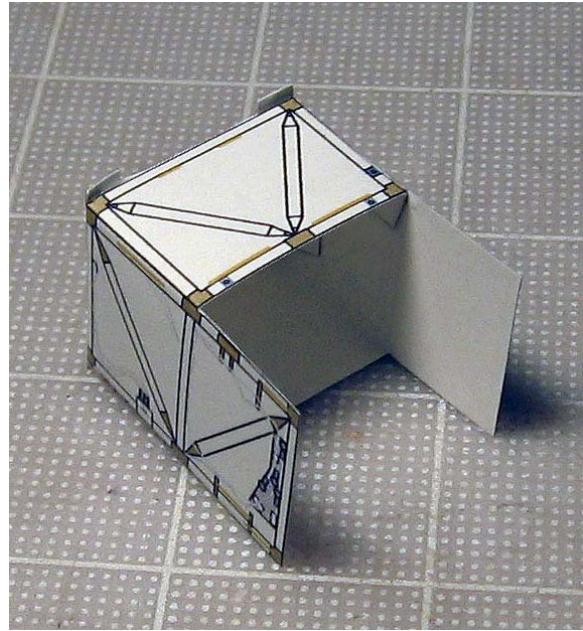
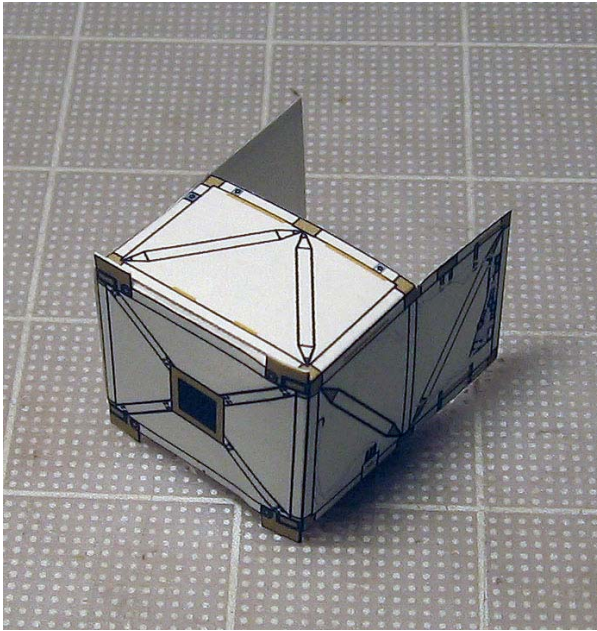



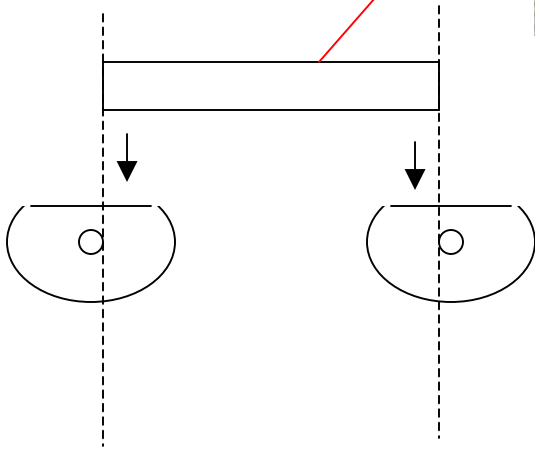
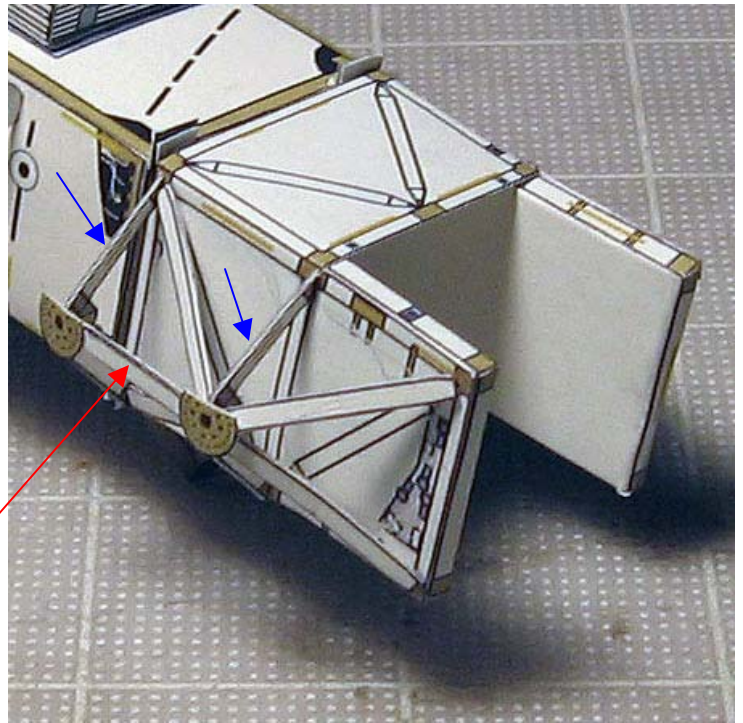
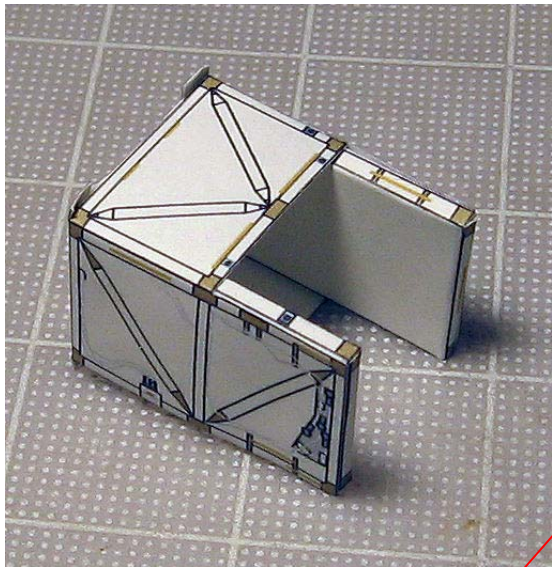
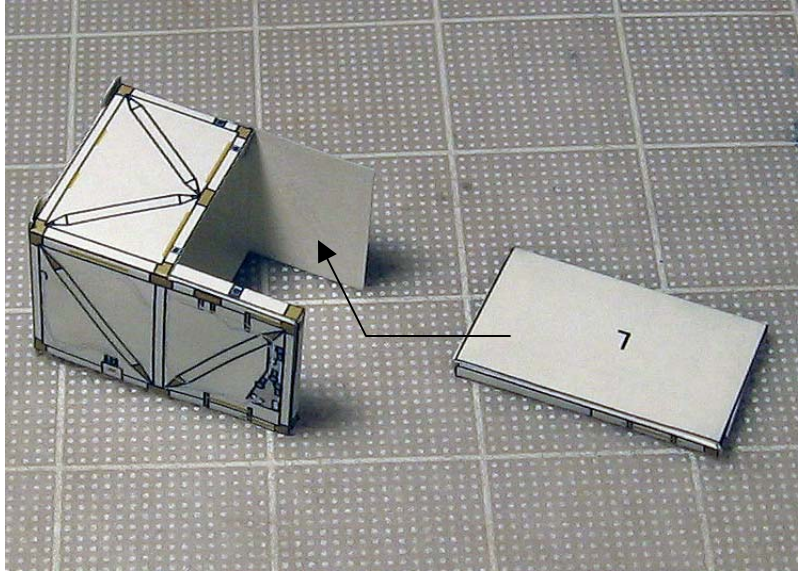
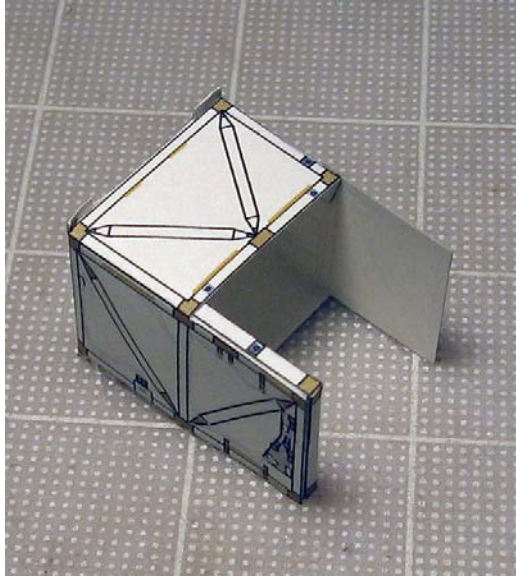

This diagram shows how the small horizontal bar (red arrow) is glued to the back of the half of each trunnion. Once the whole group is glued together, then everything is glued on top of each of the V shape parts on each side of the truss. (blue arrows)

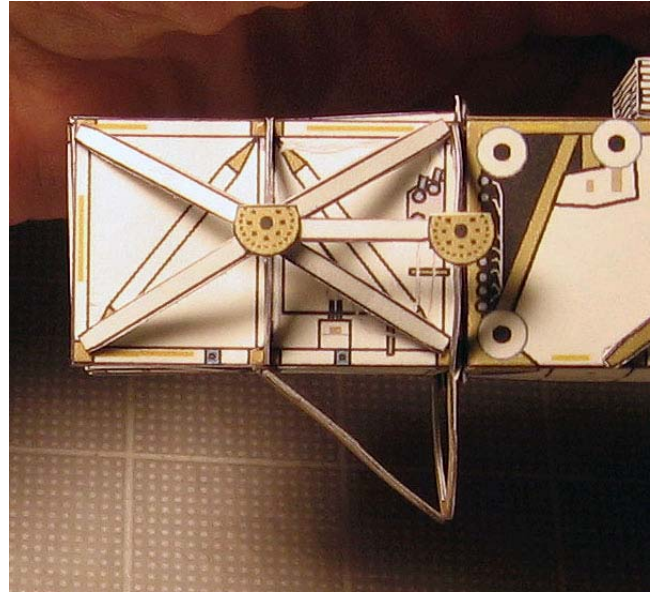
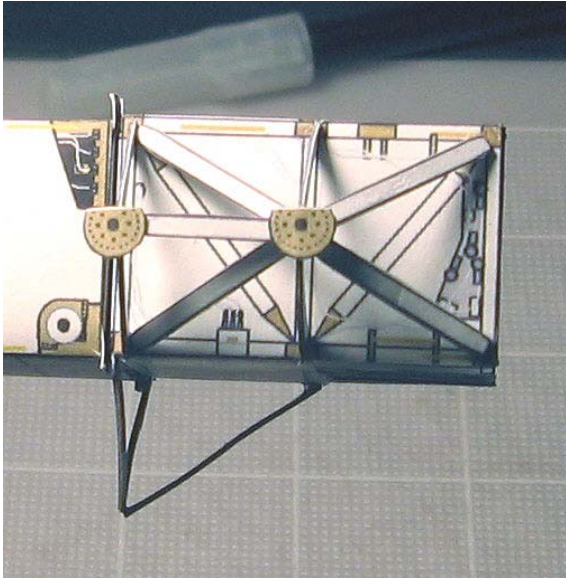

These are views from both sides. Note details how and where the rest of the white beams are placed. This model is shown already glued to the P6 truss.

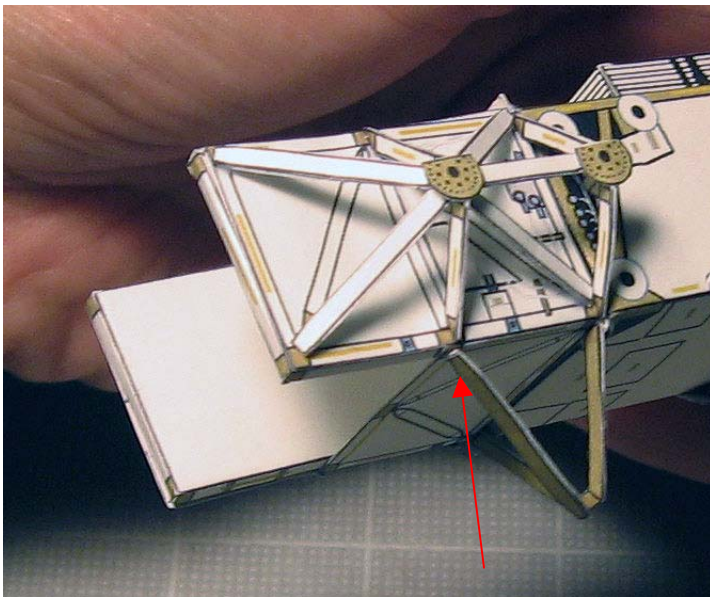

Note how the lower beam is glued to the left side of the truss.

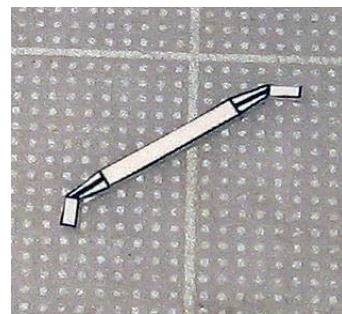
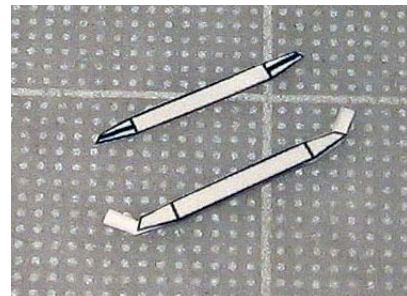

This is beam that goes on each top and bottom of the truss.

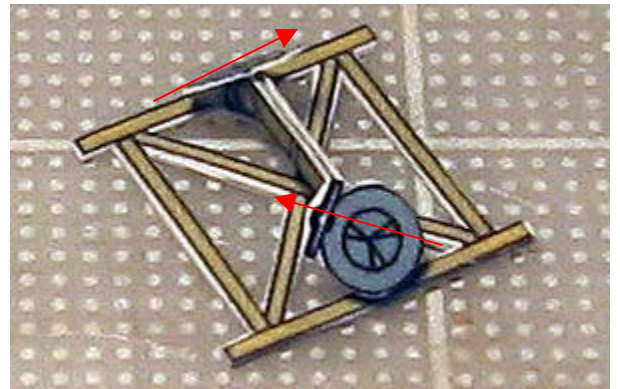
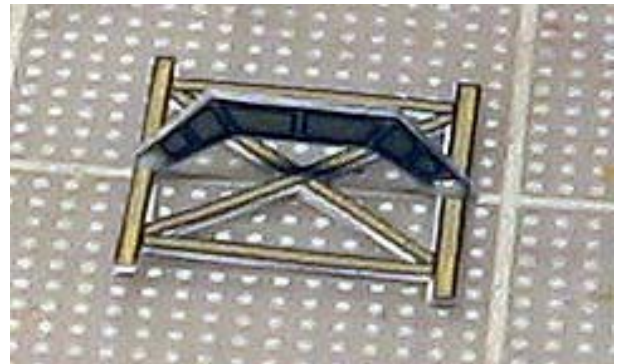
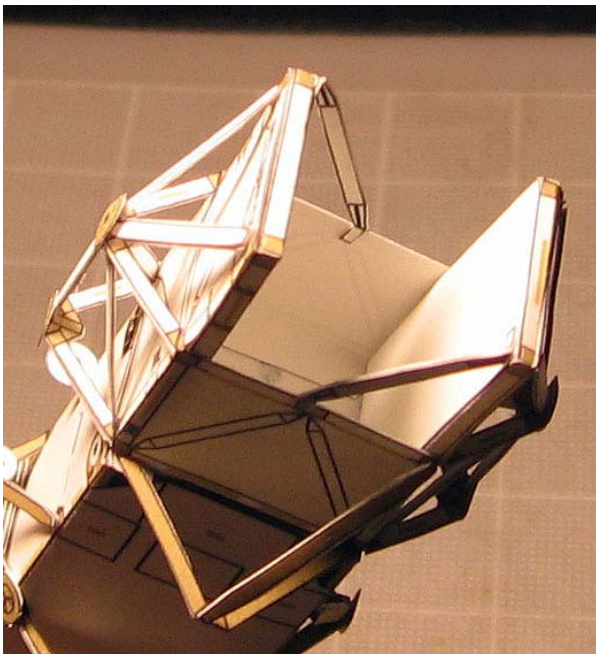
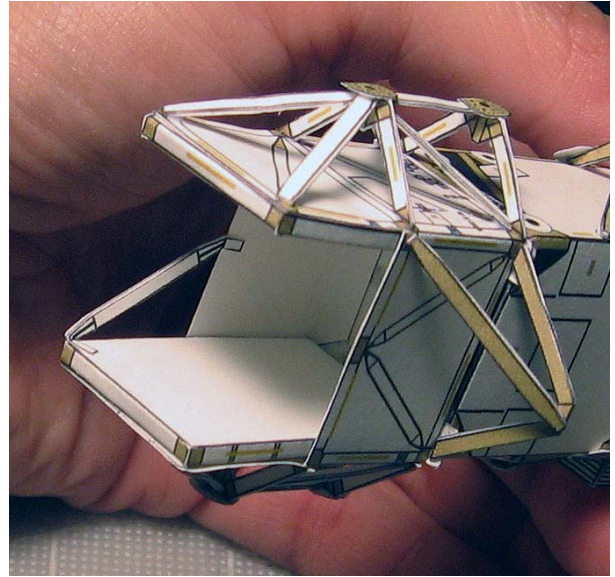
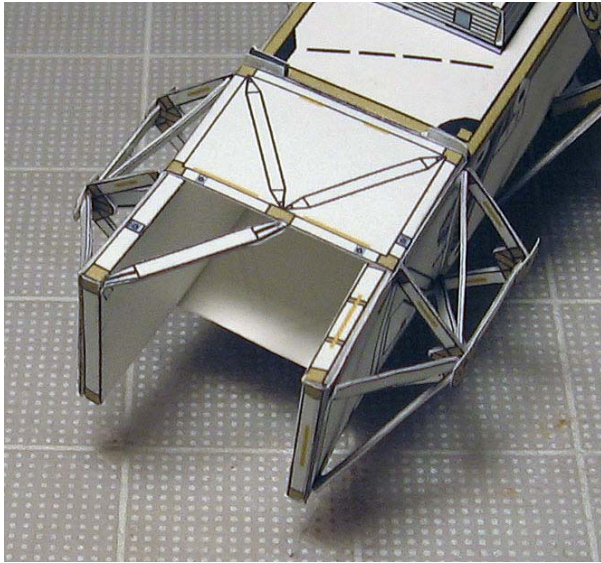

This is the PVRGF which has 2 grapple fixtures glued in opposite ways. (arrows)

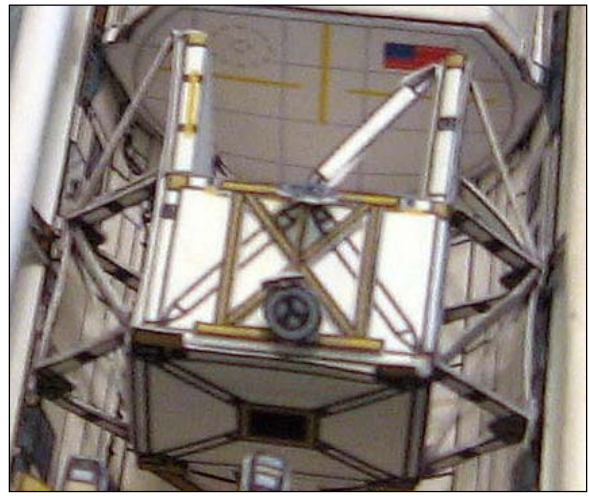
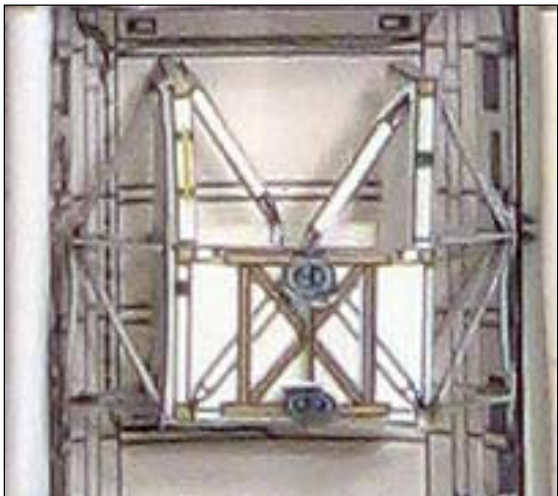

Note how the PVRGF is glued on top of the truss for payload bay configuration only.

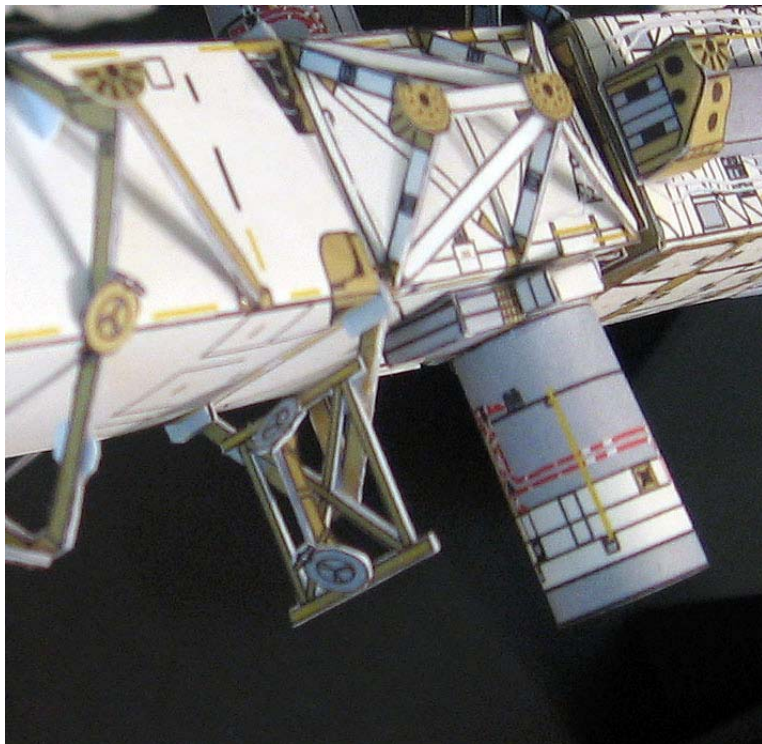

For Space Station configuration, the PVRGF is glued to the outer side of the V shape structure of the P5 truss, as shown on this photo.

## Connecting the P5 to the rest of the Space Station

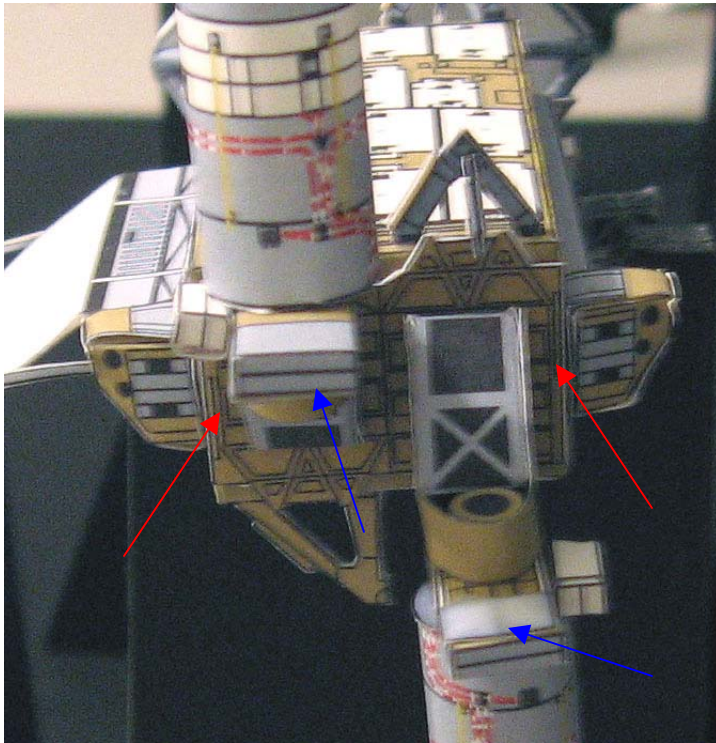

This is a view of the P4 segment truss (STS-115 mission kit). The arrows point to the areas where the P5 will be glued, on the sides to each of the solar panel canister supports.

The other areas that will hold tight the P5 truss is the upper and lower rectangular areas shown here with blue arrows.

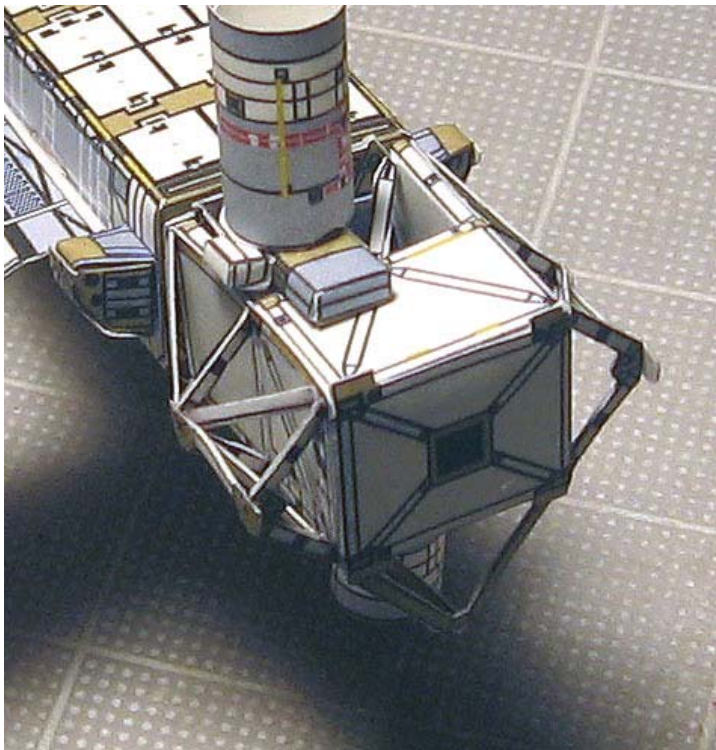

Note the details of this photo how both trusses are put together.

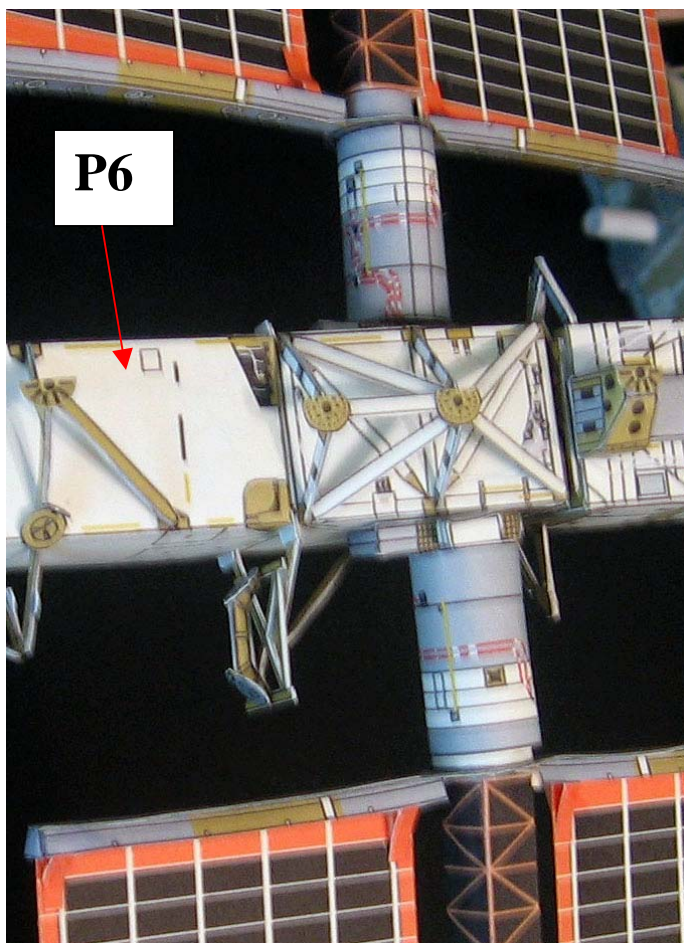
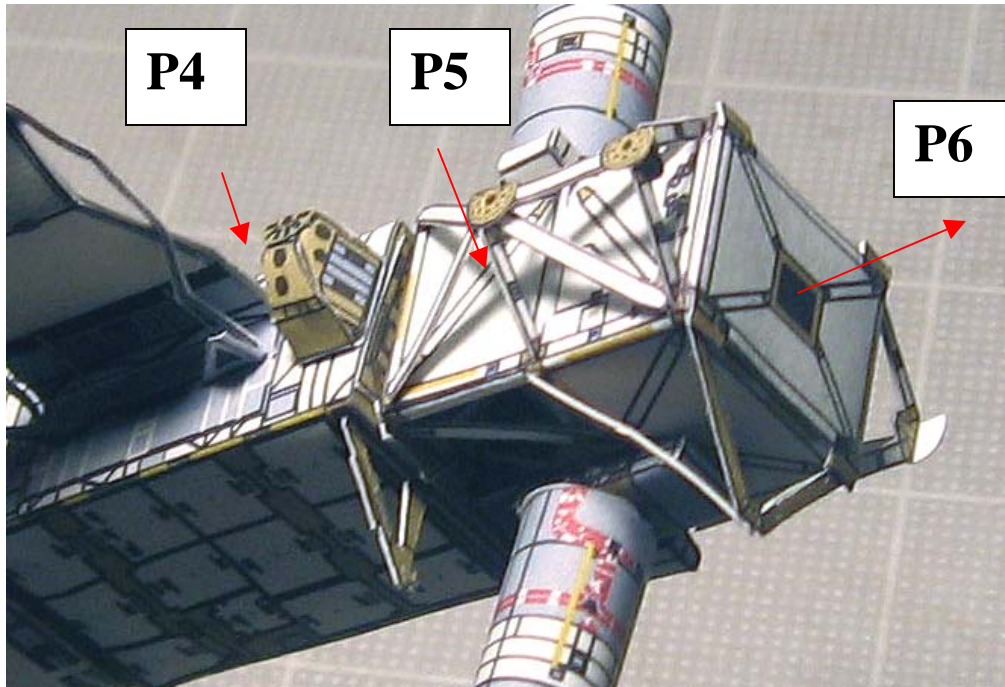

**IMPORTANT TIP:**

For better results, the best advice is to glue the P5 with the P6 together, AND THEN glue it to the end of the P4 –P3 truss.



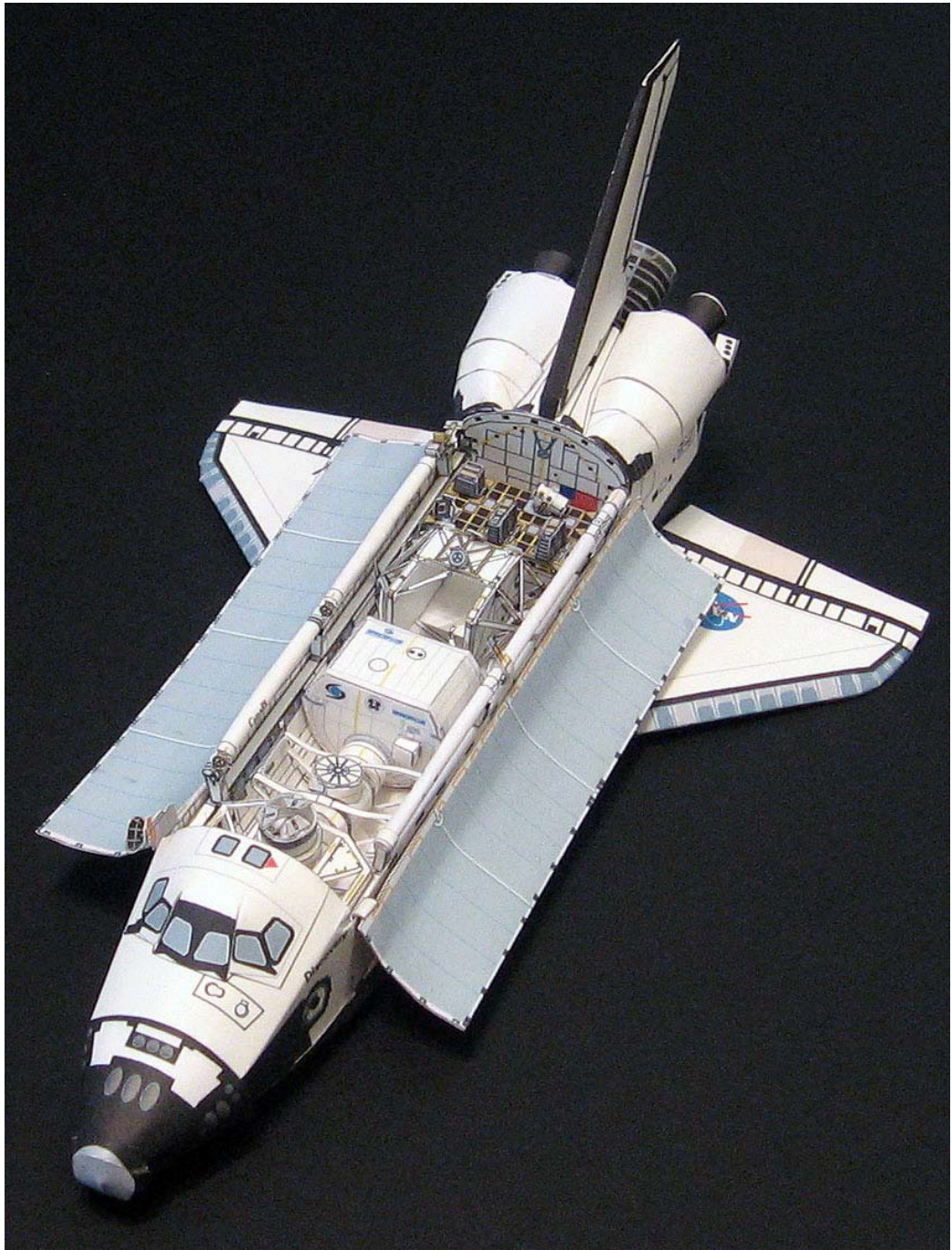



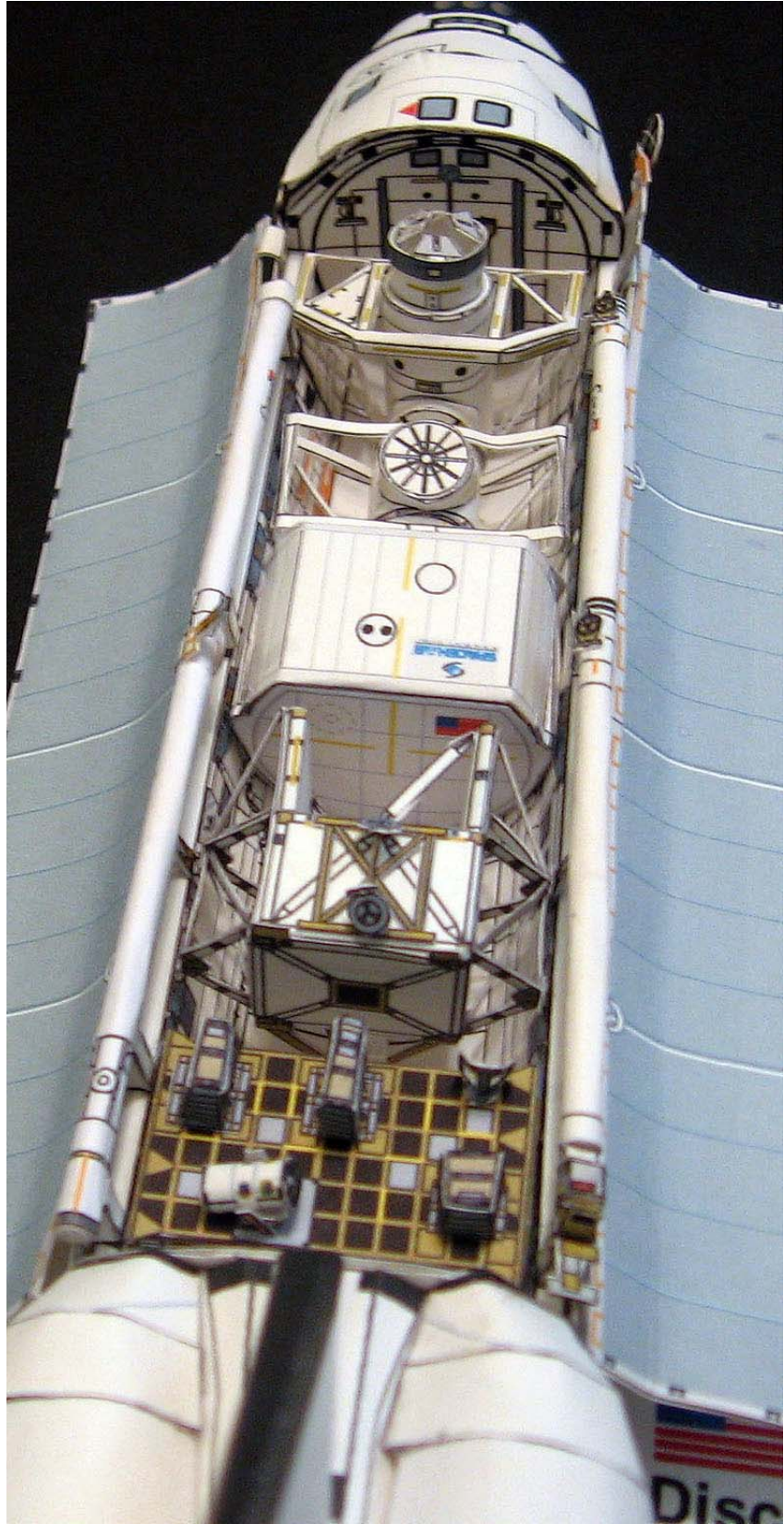

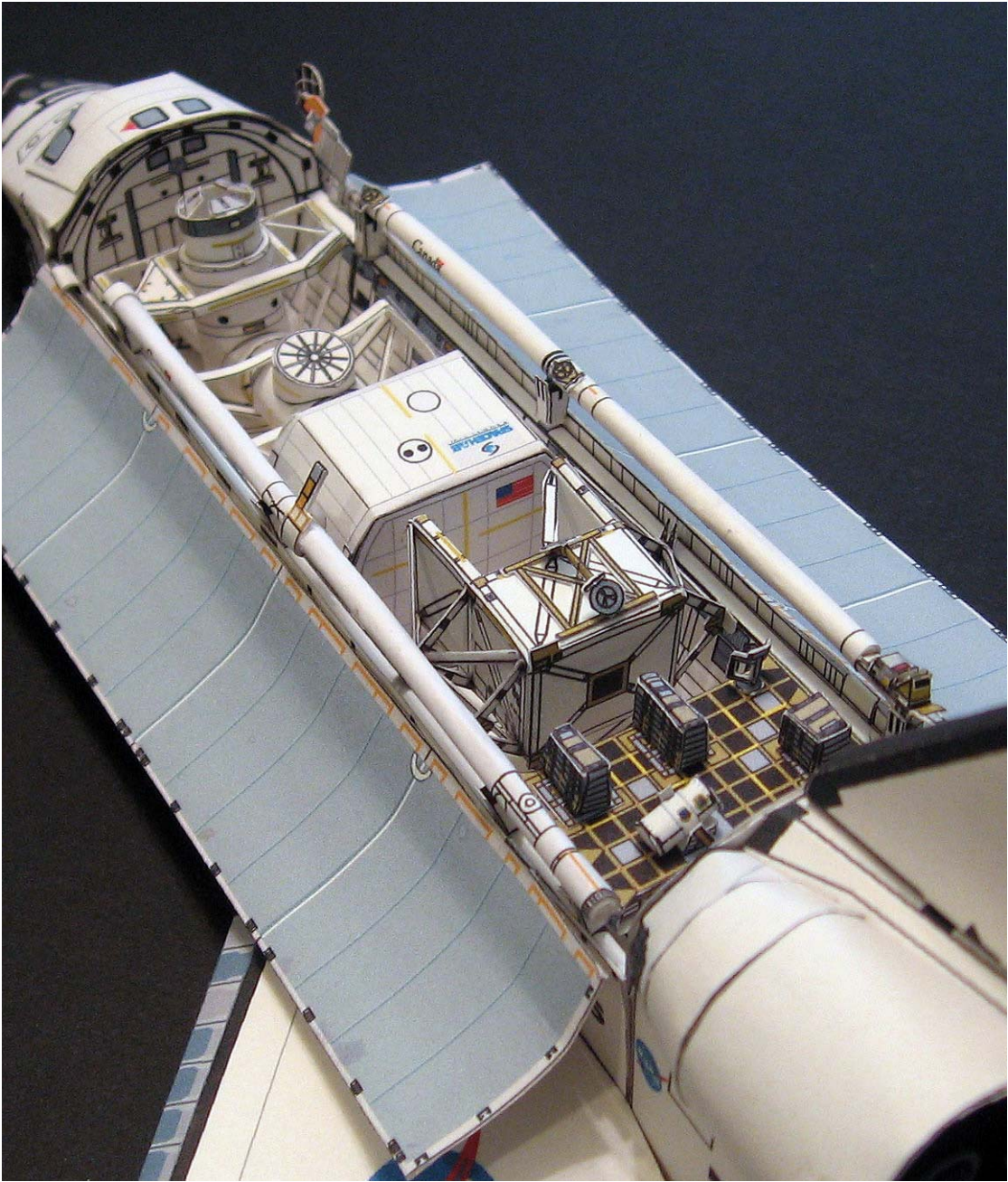

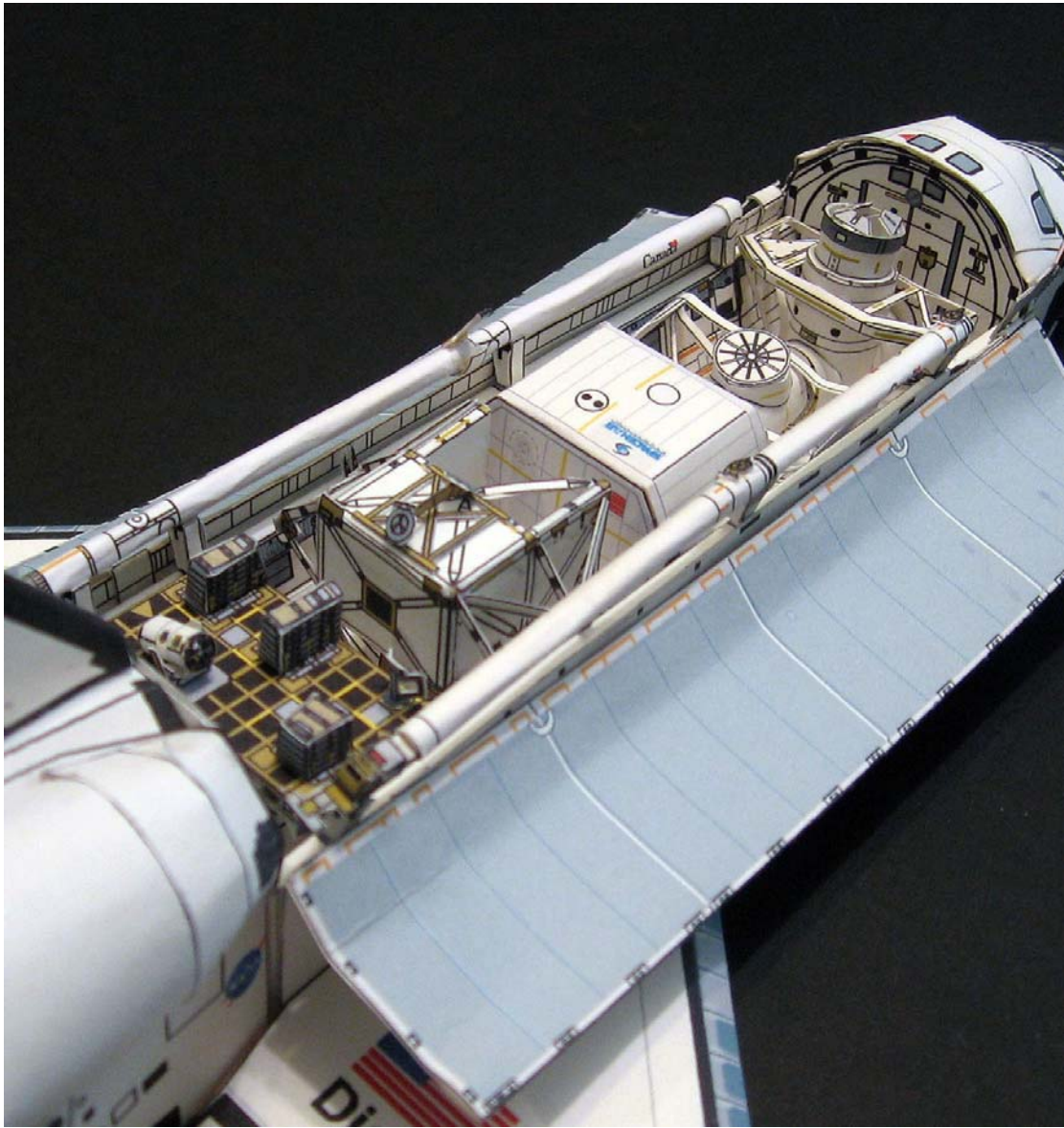

Enjoy this model!

[www.axmpaperspacescalemodels.com](http://www.axmpaperspacescalemodels.com)